

LED-Tile M25

Product Sheet



Introduction

FEATURES

- Generation 3 compatible
- Automatic Addressing System (Smart Link) – no addressing at the board
- Automatic switching between DMX and DPB protocol
- Optional bidirectional DPB protocol for feedback about temperature, voltage, etc. (Easy Feedback)
- Compatible with other series from Schnick-Schnack-Systems
- Free patch, color change and scroll text control software
- Made in Germany

- ANSI batch selection
- Wider 120° beam angle
- Camera friendly dimmer control
- Equal brightness despite different cable lengths due to integrated switching regulator
- Optimum efficiency due to state-of-the-art circuit technology

- Direct control with DMX 512-A
- Direct connection to 24V DC

- Pliable, fiberglass reinforced board
- Minimal surface temperature
- Component-free top surface for a clear, unobstructed view

Use

The Product M-Series LED-Tile is equipped with premium quality, efficient, monochrome or white LEDs. Each LED can be individually controlled and are therefore the ideal LED light source for all applications where monochrome, dynamic structures or video effects are called for. Whether as a display for single-color scrolling text, black and white videos or animated light, the M-Series LED-Tiles bring movement to walls, floors, counters, light boxes and other decorative elements.

Technology

The LED-Tile M25 measures 194mm×190mm and is equipped with 64 LEDs in a grid layout at intervals of 25mm in 11 different colors:

- Warm white (2700K, 3000K, 3500K)
- Neutral white (4000K)
- Cold white (5000K, 5700K, 6500K)
- Red
- Green
- Blue
- Amber

The pin assignment can only be found on the backside of the tile providing a clear, clean surface. The M-Series tiles can also be used without diffusers. Thanks to our Smart Link Technology elaborate addressing of the tiles is no longer necessary.

The LED-Tile M25 belongs to the Generation 3 and in addition to DMX, can also read the Dynamic-Pixel-Bus Protocol (DPB). By using the DPB, more LED-Tiles per output of a system power supply are available – up to 3,072 channels. A variable transmission rate enables the best, customized balance of channel count, frame and error rate. When using video signals, a system-wide synchronization prevents image distortions. The system speed can therefore easily reach the 60 fps update rate and switching between DMX and DPB is possible at all times.

The tile firmware can be updated from a central point via the network with the System Power Supply 4E, which also means that future standards or developments can be supported. Each tile sends status information such as temperature, data error rate, input voltage or LED defects back to the control system so a problem-free remote diagnosis can be made at any time.

The M25 LED-Tiles can be mounted with board holders.

Control

The power supply and addressing takes place via the System Power Supply 4E. Via its Ethernet interface, Pixel-accurate control of the M-Series LED Tiles can be achieved with lighting boards, media servers, with our Pixel-Gate video converter as well as DVI or SDI video signals.

Mechanical data

Features	LED-Tile M25
Dimensions	194mm × 190mm
LED-Pitch	25mm
Number of LEDs	64
Pin connection and -colour	System connector red
Safety class	IP00
Weight	180g

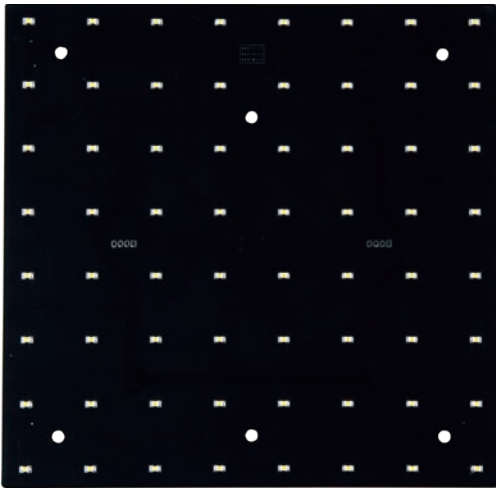

LED-Tile M25 (front view)

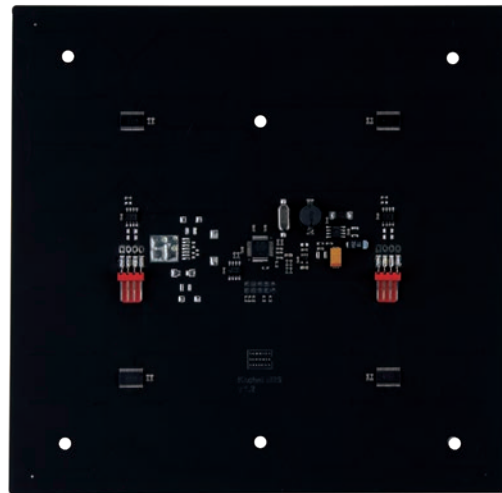

LED-Tile M25 (rear view)

CAD drawing*

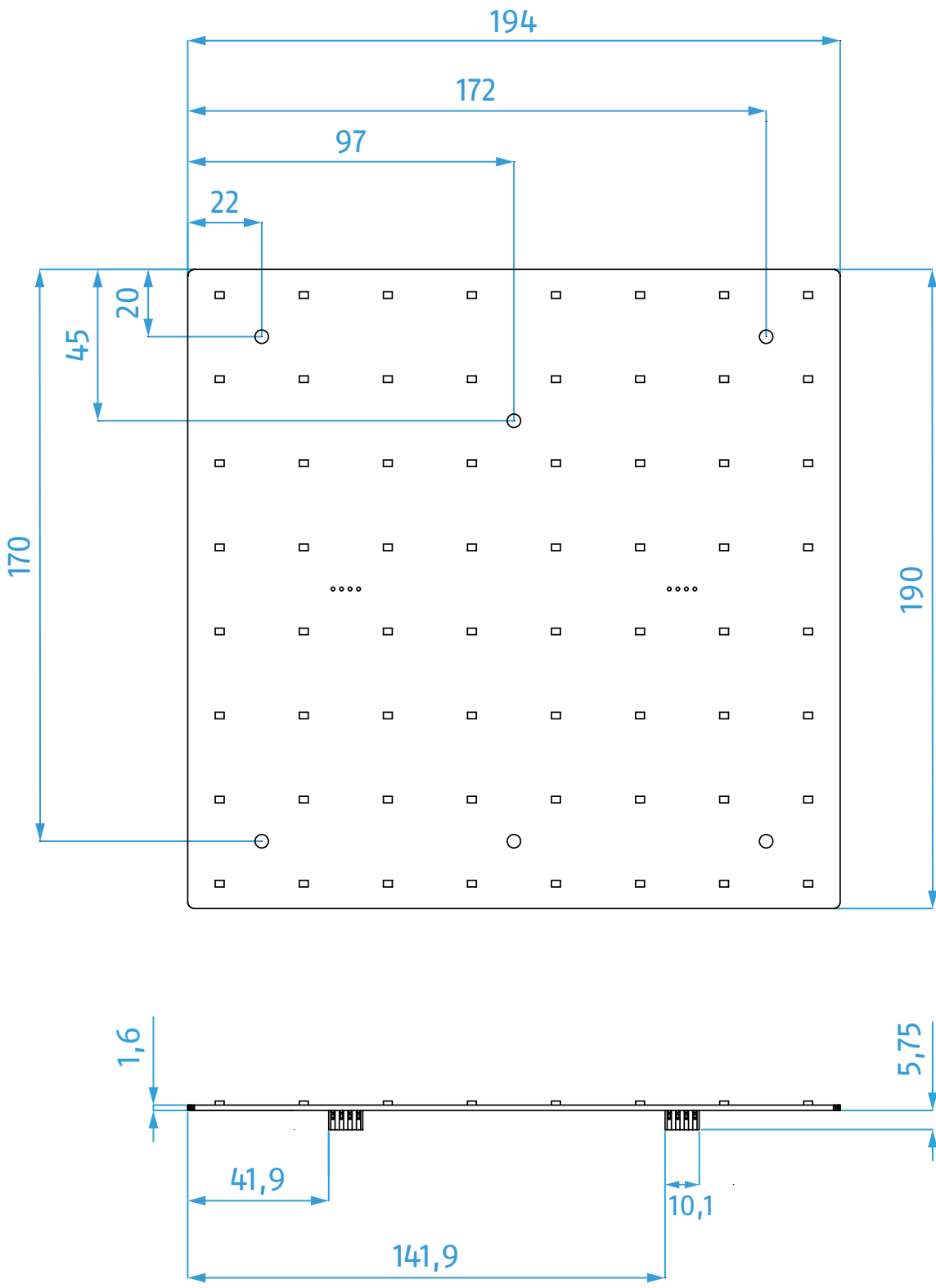

* without scale / all units in mm

Optical data

Features	LED-Tile M25
Colour	2700K-6500K Red Green Blue Amber
Emission angle	120°
Lighting current	400,1lm*
Colour reproduction R _a	> 80*
Light intensity	127,4cd*

Distance/Lux table

Distance	Lux
0,5m	509,4lx*
1m	127,4lx*
2m	31,8lx*

* The data provided are measured values. As these values are subject to fluctuations, the actual values of the delivered LEDs may deviate from them. The photometric values were measured using an LED-Tile M25 in white (red, green, blue and amber on request).

Light distribution curves

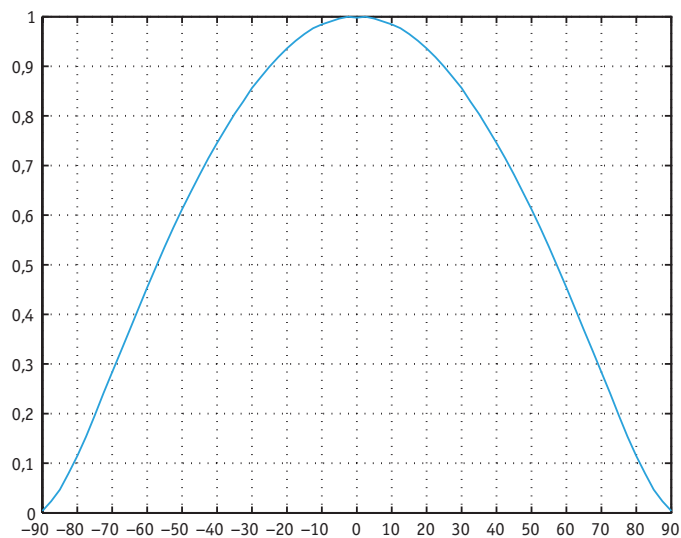
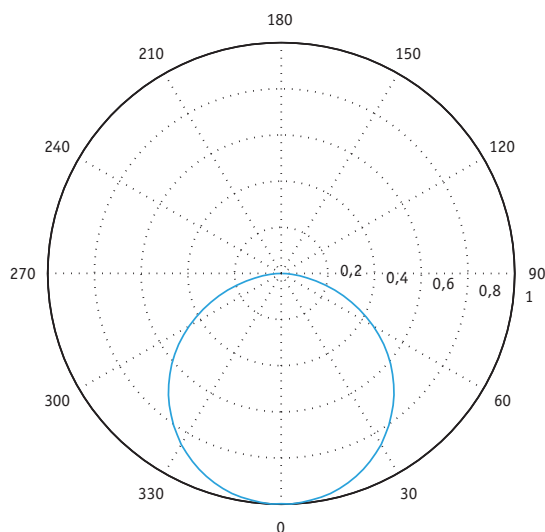

Binning (ANSI)

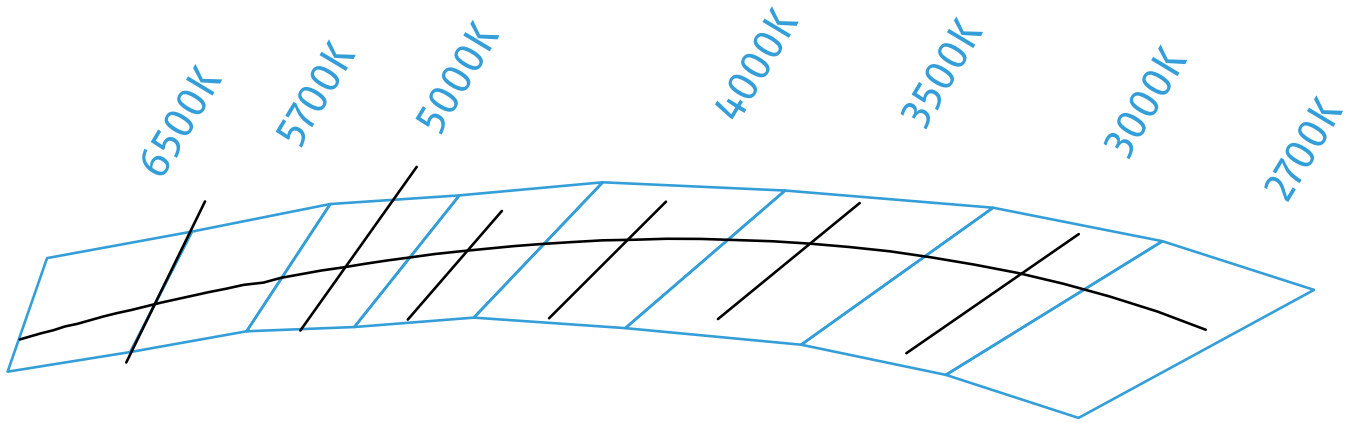

Spectral distribution

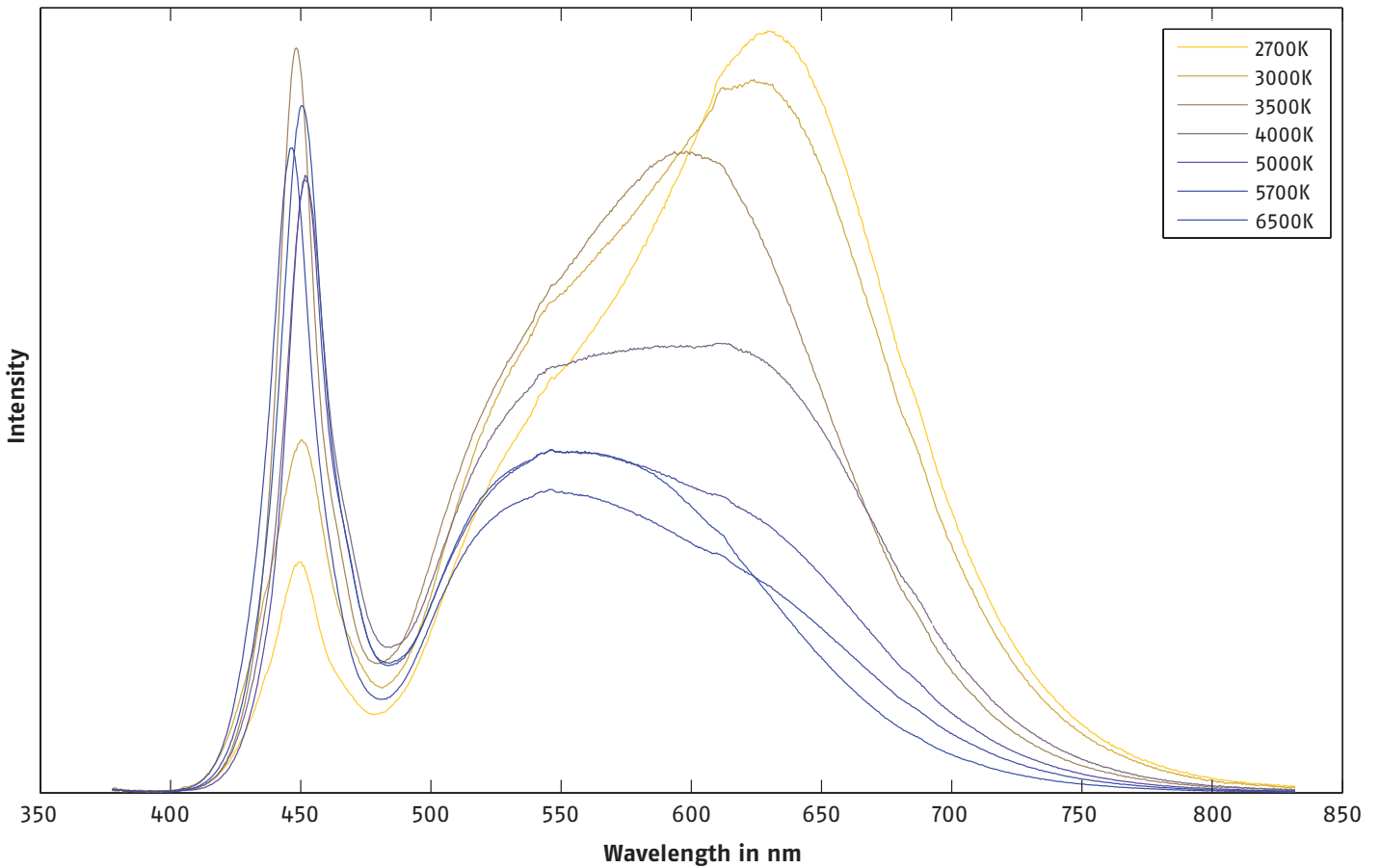

Mounting

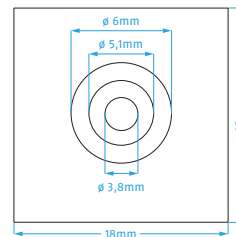
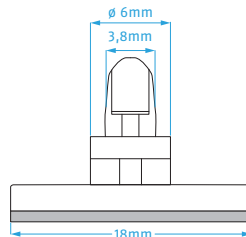
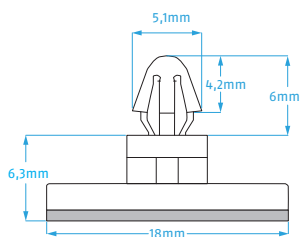
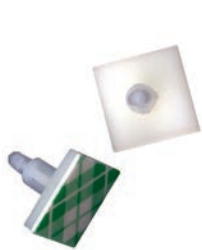

Description

PCB holder 6mm, self-adhesive version

Item number

802.0001

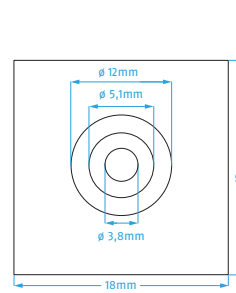
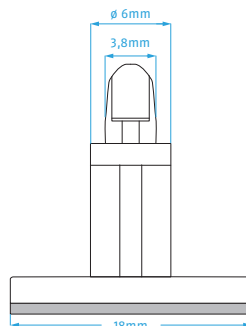
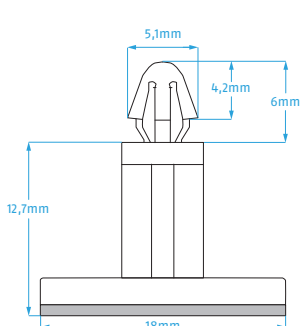

Description

PCB holder 12mm, self-adhesive version

Item number

802.0002

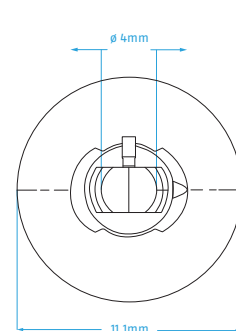
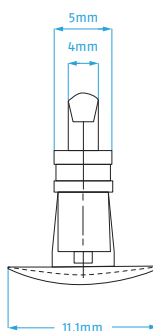
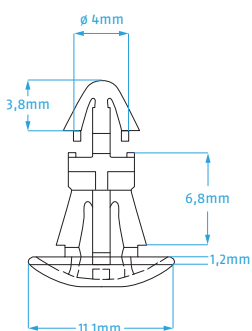

Description

PCB holder 6mm, Plug-in version (for plates)

Item number

802.0003

Drill hole

5,4mm

Material thickness

1,5-1,6mm

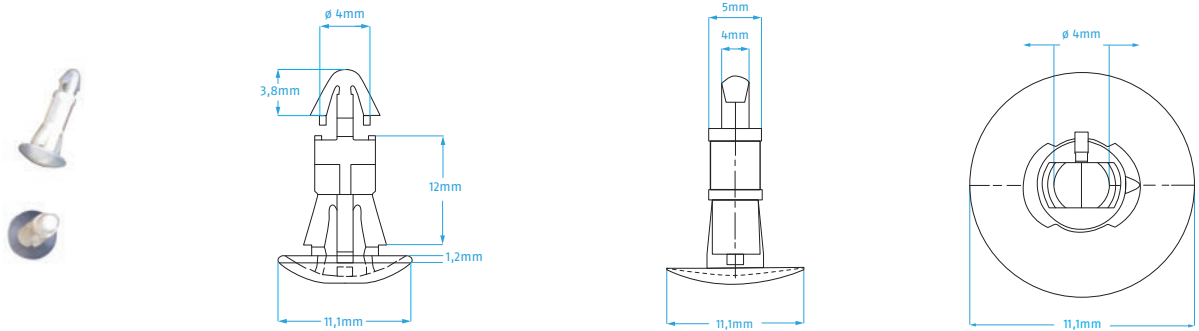

Description	Item number	Drill hole	Material thickness
PCB holder 12mm, Plug-in version (for plates)	802.0004	5,4mm	1,5-1,6mm

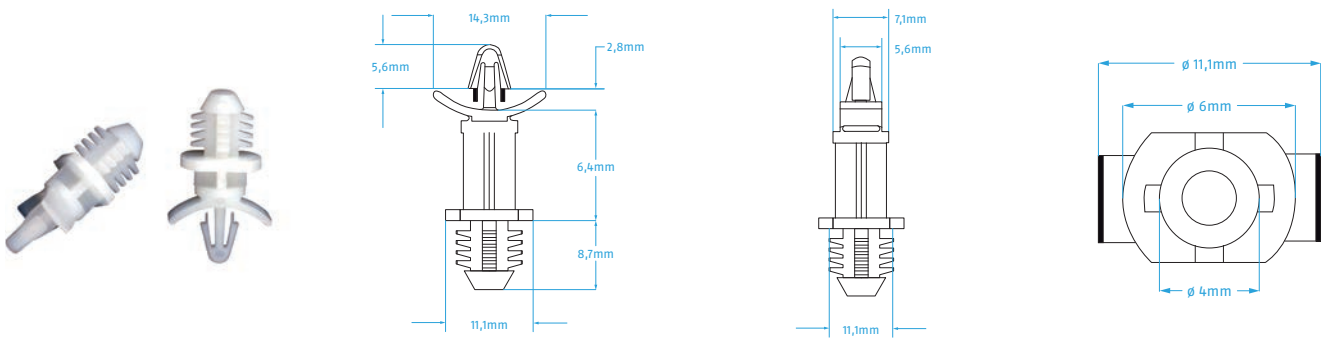

Description	Item number	Drill hole	Material thickness
PCB holder 6mm, drill version (for wood or plastic)	802.0006	7,9mm	minimum 6,4mm

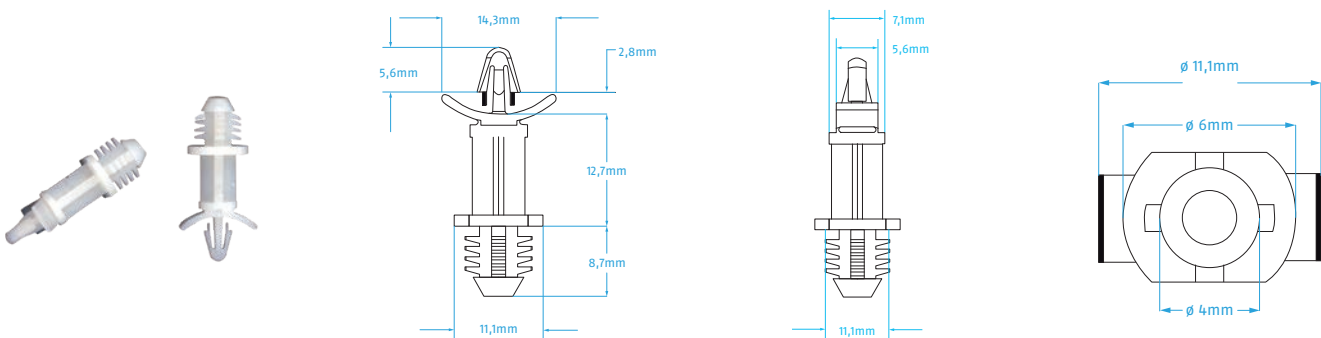

Description	Item number	Drill hole	Material thickness
PCB holder 12mm, drill version (for wood or plastic)	802.0007	7,9mm	minimum 6,4mm

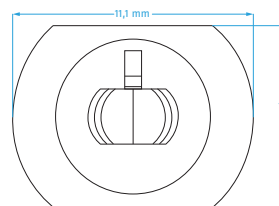
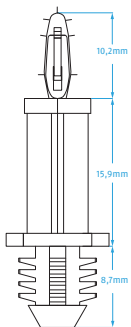

Description	Item number	Drill hole	Material thickness
PCB holder 16mm, drill version (for wood or plastic)	802.0008	7,9mm	minimum 6,4mm

Electrical data

Features	LED-Tile M25
Voltage	24V
Current (I_{\max} White)	0,5A
Current (I_{\max} Red and Amber)	0,5A
Current (I_{\max} Green and Blue)	0,5A

Pin Connection

System connector red

1	■	GND
2	■	DMX -
3	■	DMX +
4	■	24 V

Control options for LED-Tiles M25

System Power Supply 4E



DMX 512*

maximum 32 LED-Tiles per controller
 maximum 8 LED-Tiles per XLR output
 maximum 6 LED-Tiles per System connector red

DPB**

maximum 48 LED-Tiles per controller
 maximum 12 LED-Tiles per XLR output
 maximum 6 LED-Tiles per System connector red

*channel-restricted

**current limited

Cabling example for System Power Supply 4E with LED-Tile M25

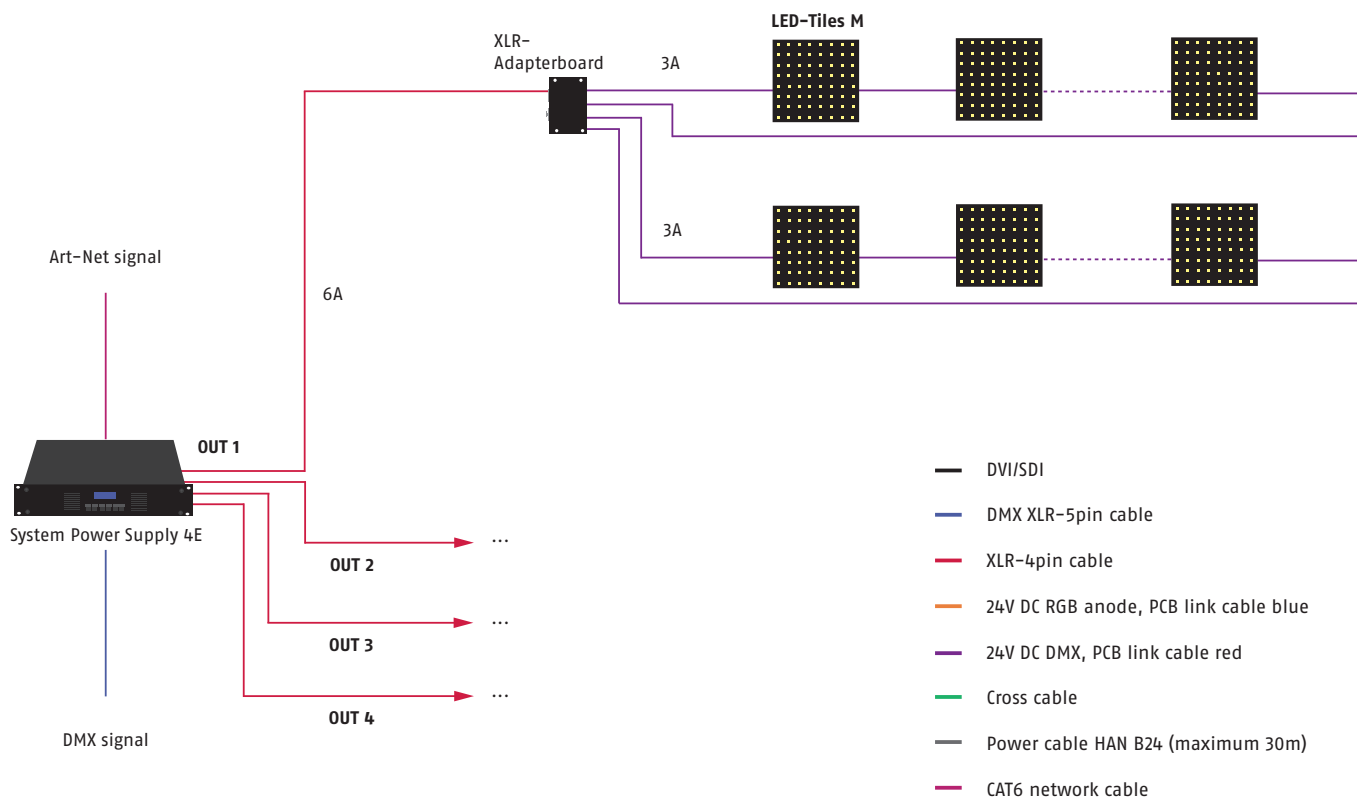

DPB Pixel-Router



DPB

maximum 24 LED-Tiles per controller
 maximum 6 LED-Tiles per output

Cabling example for DPB Pixel-Router with LED-Tile M25

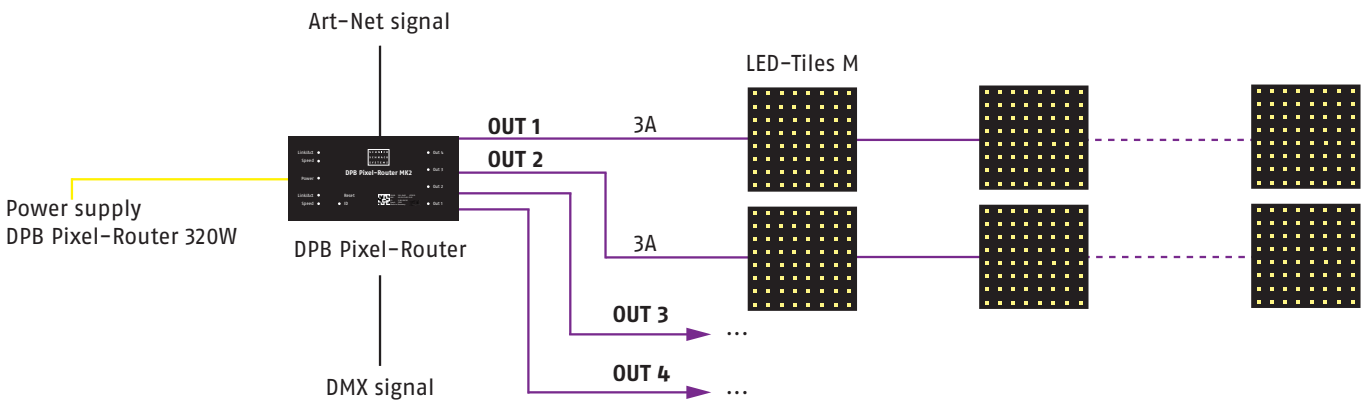

- DVI/SDI
- DMX XLR-5pin cable
- XLR-4pin cable
- 24V DC RGB anode, PCB link cable blue
- 24V DC DMX, PCB link cable red
- Cross cable
- Power cable HAN B24 (maximum 30m)
- CAT6 network cable

Order numbers

	LED-Pitch	Backlighted surface	Current (I_{max})	Channels	Connection	Colour	Item number
LED-Tile M25	25mm	200mm × 200mm	0,5A	64	System connector red	6500K	114.6512
						3500K	114.3512
						3000K	114.3012
						5700K	114.5712
						5000K	114.5012
						4000K	114.4012
						2700K	114.2712
						Red	114.0042
						Green	114.0082
						Blue	114.0092
						Amber	114.0052

	Operating voltage	Power (I_{max})	Channels	Input	Output	Item number
System Power Supply 4E	110-240V AC	4 × 6A*	4 × 3072 channels (DPB)	Ethercon RJ 45	4 × XLR-4pin	203.0003
			4 × 512 channels (DMX)	XLR-5pol IN/Trough		
DPB Pixel-Router MK2	24V DC	4 × 3A	4 × 3072 channels	RJ 45	4 × System connector red	203.0021
DPB Pixel-Router POE MK2	24V DC	4 × 3A	4 × 3072 channels	RJ 45	4 × System connector red	203.0022

* Note: american version only 4 × 4A at 110V

ESD warning

Please be aware that electrostatic discharges can destroy LED boards, and our experience shows that this does happen. During assembly, we recommend wearing at least one antistatic wrist strap and avoiding static discharges – such as those that arise when removing protective film or dry cleaning acrylic glass, for example – near LEDs! Antistatic materials should be used when packaging the LED boards. Normal bubble wrap or other plastic bags are not suitable.

For reasons of safety and radio shielding, please only use systems we have approved to provide a power supply for our LED components. All technical information is based on the version at the time of printing.

We reserve the right to make technical specifications in terms of a product improvement without prior notice. Printing – even excerpts – requires the written consent of Schnick-Schnack-Systems GmbH.

Why Schnick Schnack Systems?

As installation times become increasingly shorter the complexity of systems simultaneously increases as do the requirements of customers.

We are a supplier who delivers high-quality reliable systems – under tight deadline constraints that are not only quick to install but also simple to operate and service.

Schnick-Schnack-Systems GmbH

Mathias-Brüggen-Straße 79
50829 Cologne (Germany)

Phone +49 (0) 221/99 2019-0
Fax +49 (0) 221/16 85 09-73

info@schnickschnacksystems.com
www.schnickschnacksystems.com

© 2018 Schnick-Schnack-Systems GmbH

Version February 2018: All technical data and the weight and dimension information were carefully created – errors reserved. Any colour deviations are printing-related.

We reserve the right to make changes that serve further improvement.