

# C-Dot and Intelligence C20

Product Sheet



# Introduction

## FEATURES

- Generation 3 compatible
- Automatic Addressing System (Smart Link) – no addressing at the board
- Automatic switching between DMX and DPB protocol
- Optional bidirectional DPB protocol for feedback about temperature, voltage, etc. (Easy Feedback)
- Display in the absence of control signal
- Compatible with other series from Schnick-Schnack-Systems
- Free patch, color change and scroll text control software
- Made in Germany
- Design cost efficient, large surfaces

- Freely arrange single LEDs
- Premium quality LEDs
- Individual color calibration of fitted LEDs
- Subsequent calibration possible
- Optimum RGB color mixing in an SMD-component (no colored shadows)
- Wider 115° beam angle
- camera friendly dimmable
- Equal brightness despite different supply-line lengths due to integrated switching regulator
- Enough "headroom" for longer durability

- Direct control with DMX 512-A
- Direct connection to 24V DC

- Minimal surface temperature
- Versatile mounting options

## Use

The product C-Series LED-Dots are equipped with premium quality, efficient RGB LEDs. Each LED can be controlled individually and arranged freely opening up new and even more creative design possibilities. Since the Dots are not bound to a fixed grid, it's possible to create different kinds of forms and structures – whether its single points, lines or surfaces. That's why they are the ideal LED light source for all uses where freely formed elements with video, scrolling text or light gradients should be animated. The C-Dots can be combined easily with any other C-Series products, for example when a particular lighting situation so requires. By combining the C-Dots with acrylic rods, three-dimensional ceilings or wall areas can be created easily and cost-efficiently.

## Technology

The C-Dot is available with a beam angle of 110°. Dots and Intelligence C20 are connected with a network cable. The maximum length of the cable is 10 meters. Each Dot is individually color-calibrated so more precise shades of white and pastels can be achieved. What's more, the LED Dots are dimmable making them more camera-friendly. Thanks to the Smart Link Technology, elaborate addressing of the individual dots is eliminated.

The Intelligence C20, which is required to control the Dots, belongs to Generation 3. In addition to DMX, it can also read the Dynamic-Pixel-Bus (DPB) protocol. By using the DPB more Intelligences, and therefore more dots per output of a system power supply, are possible – up to 3, 072 channels. A variable transmission rate enables the best, customized balance of channel count, frame and error rate. When video signals are used, a system wide synchronization prevents any image distortion and the system speed can therefore easily reach the 60 fps update rate. Switching between DMX and DPB is possible at all times without any disruption.

The tile firmware can be updated from a central point via the network with the System Power Supply 4E, which also means that future standards or developments can be supported. Each Intelligence sends status information such as temperature, data error rate, input voltage or LED defects back to the control system. This enables problem-free remote diagnosis.

The LED Dots can be fastened to the subsurface with board holders or screws.

## Control

The C-Series LED-Dots are controlled with the Intelligence C20. Power is drawn from the System Power Supply 4E, the DPB Pixel-Router or the Sys One – or via an appropriate power supply for smaller installations. Pixel-accurate control of the M-Dots can be achieved with lighting boards, media servers or with our Pixel-Gate video converter via the Ethernet interface of the System Power Supply 4E.

# Mechanical data

## C-Dot

### Features

Length	10m
LED-Pitch	no fixed pitch
Number of RGB LEDs	1
Pin connection and -colour	network connector RJ45
Safety class	IP00
Weight C-Dot	5,3g
Weight C-Dot (with cover panel)	32g

## Intelligence C20

### Features

Dimensions	176mm × 116mm
Connection	System connector red RJ45 socket as output for LEDs
Weight Intelligence C20	160g



C-Dot (front view)



C-Dot (Rear view)

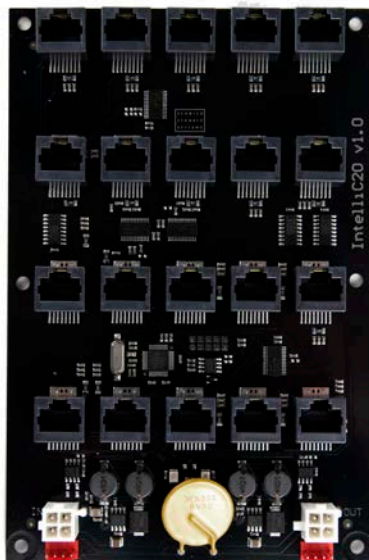

Intelligence C20 (front view)

# CAD drawing\*

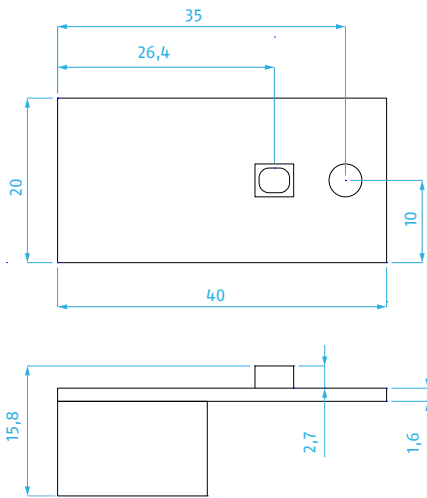

C-Dot, output at 90°

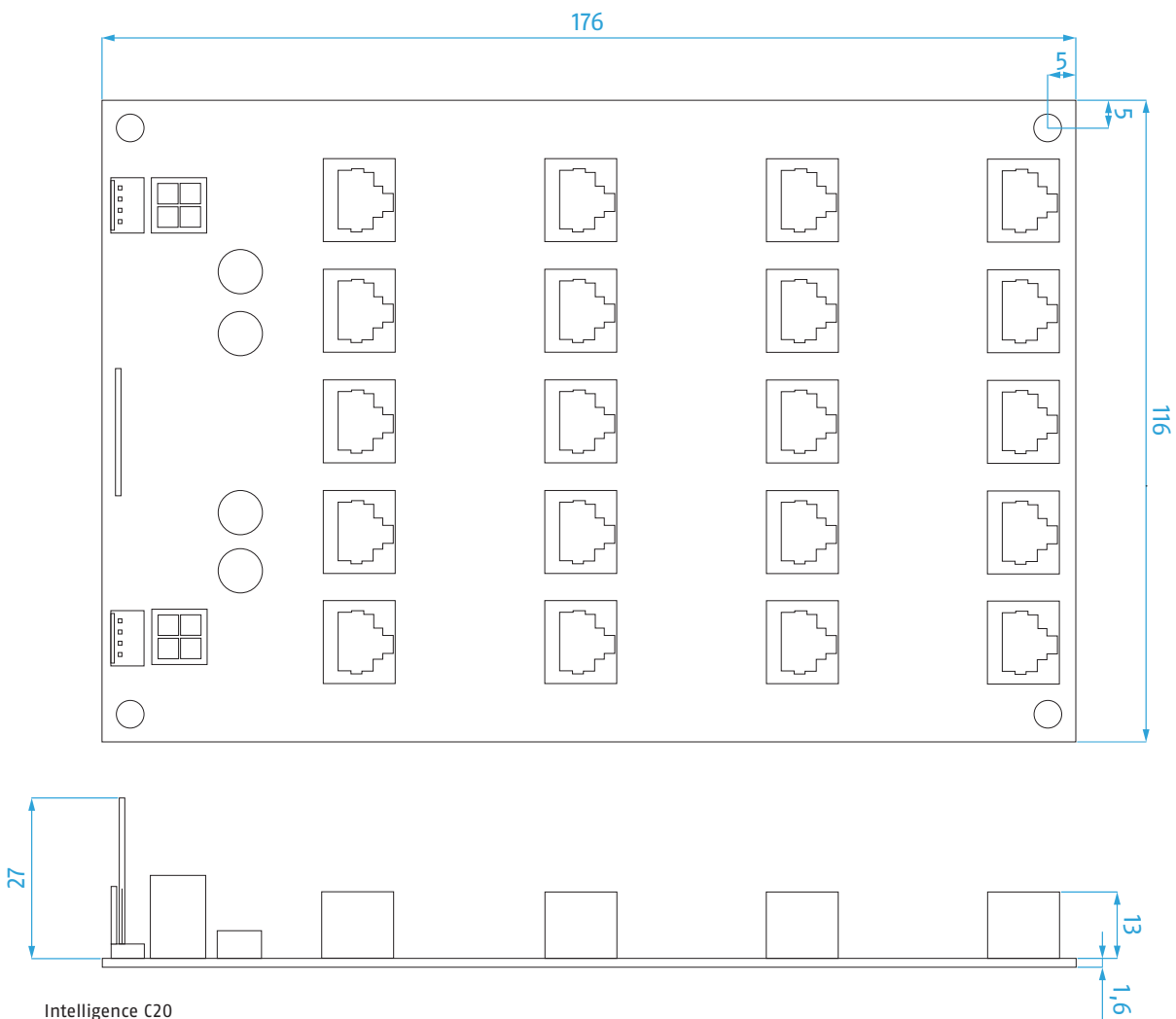

Intelligence C20

\* without scale / all units in mm

# Optical data

Features	C-Dot
Colour	RGB
Emission angle	110°
Lighting current	5lm*
Light intensity	2cd*

## Distance/Lux table

Distance	Lux
0,5m	7lx*
1m	2lx*
2m	0,25lx*

\* The data provided are measured values. As these values are subject to fluctuations, the actual values of the delivered LEDs may deviate from them. The photometric values apply to full white with RGB = 255.

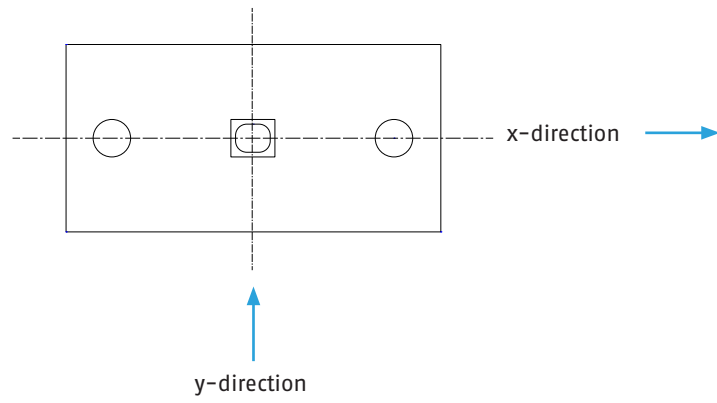

**Light distribution curves, x-direction**

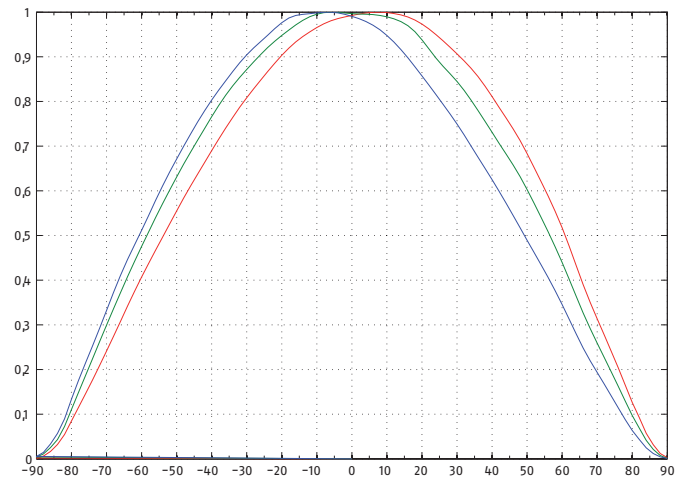
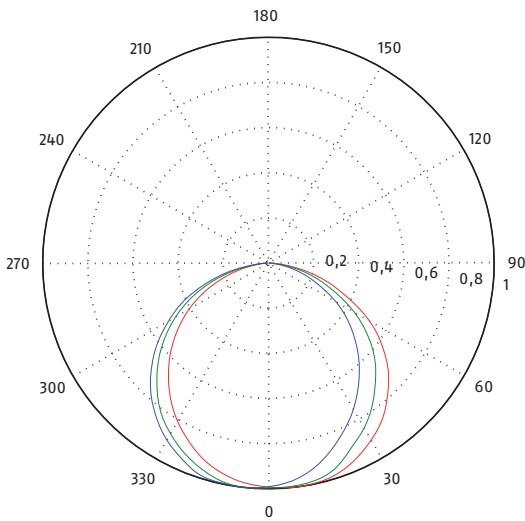

**Light distribution curves, y-direction**

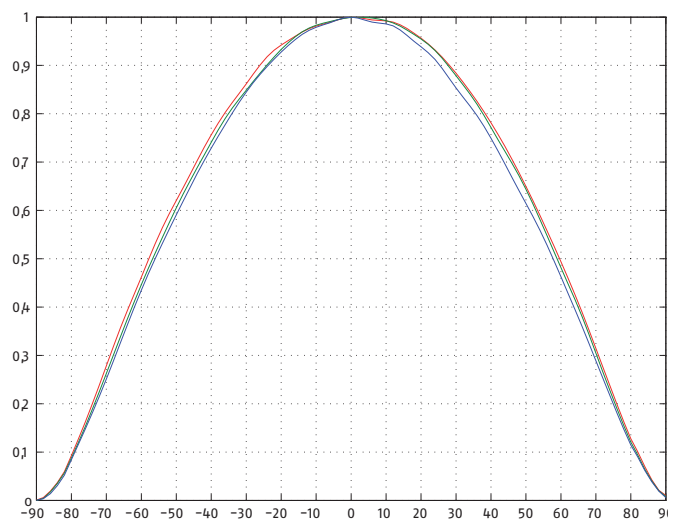
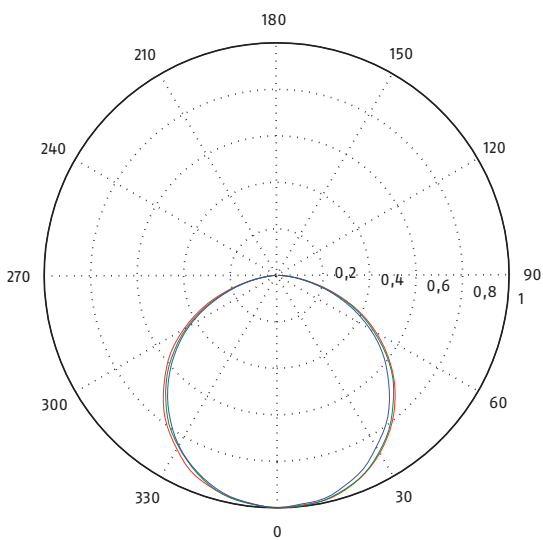

**Gamut diagram**

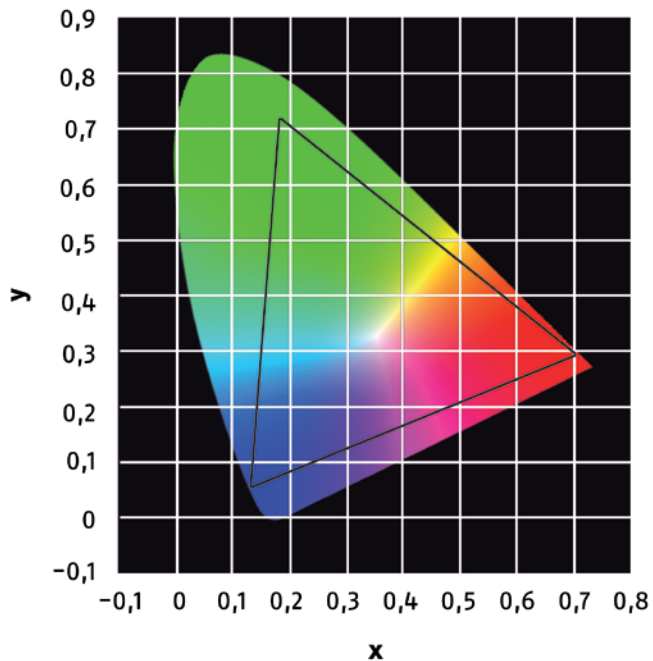

**Spectral distribution**

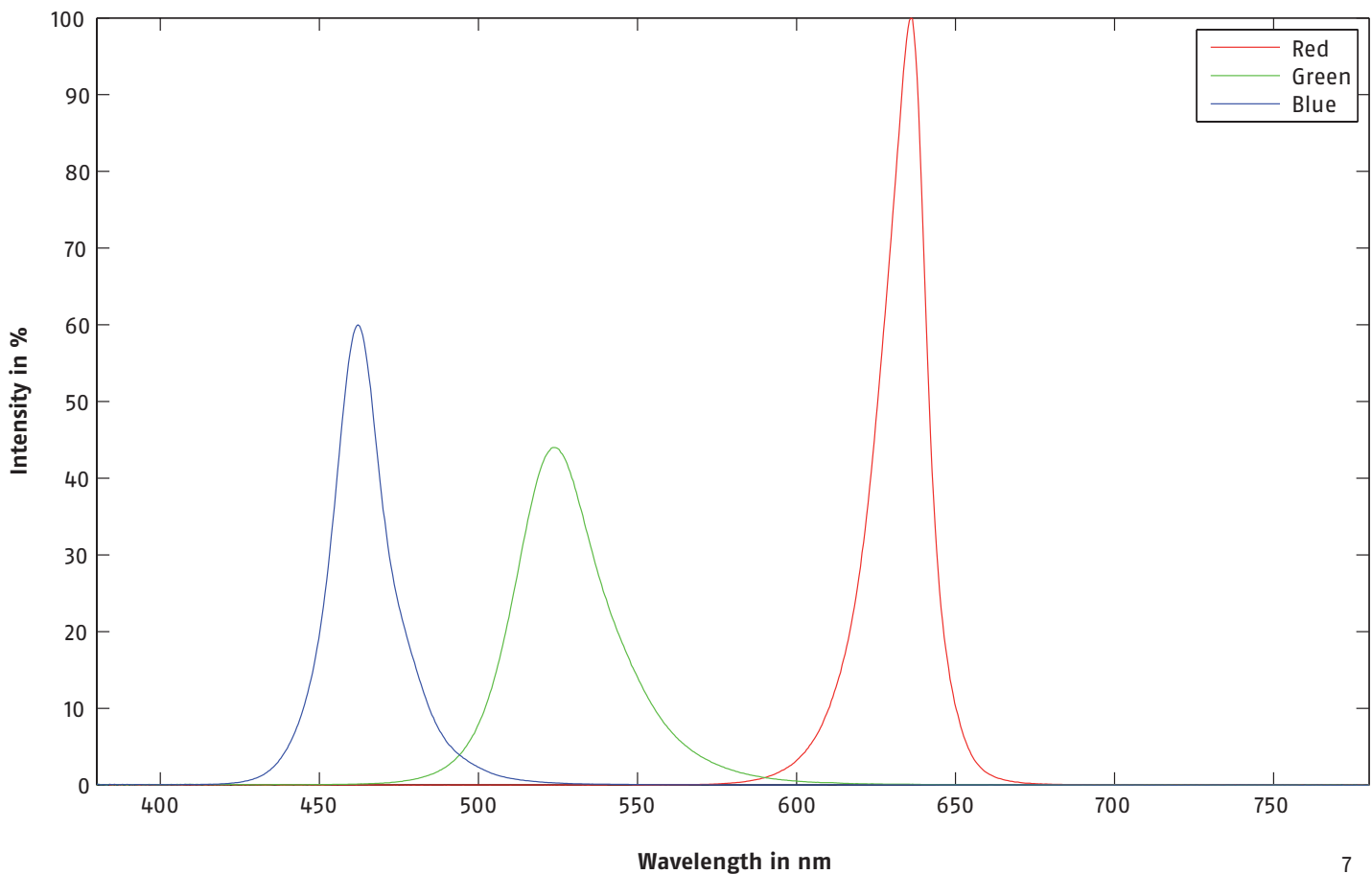

# Connecting C-Dots to the Intelligence C20



C-Dot No. 1

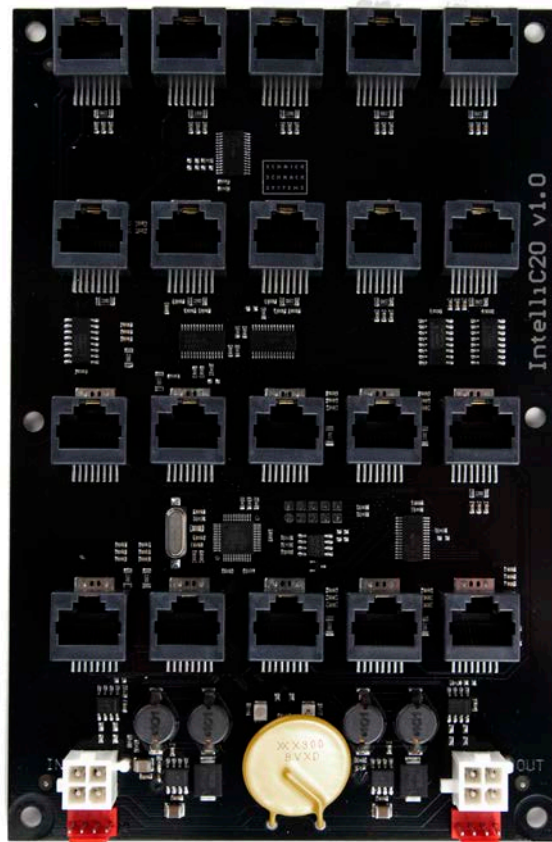

C-Dot No. 20





# Electrical data

Features	Intelligence C20	C-Dots
Voltage	24V DC	5V DC
Current ( $I_{max}$ )	0,4A (0,1A auxiliary power + 60 Channels × 5mA @ 24V)	0,015A

# Pin Connection

## System connector red



## AMP Pin Strip 4pin (maximum 6A)



# Control options for Intelligence C20 and C-Dot

## System Power Supply 4E



	DMX 512*	DPB**
Intelligence C20	maximum 32 Intelligences C20 per controller maximum 8 Intelligences C20 per XLR output maximum 7 Intelligences C20 per system connector red	maximum 56 Intelligences C20 per controller maximum 14 Intelligences C20 per XLR output maximum 7 Intelligences C20 per system connector red
C-Dot	maximum 640 C-Dots per controller maximum 160 C-Dots per XLR output maximum 140 C-Dots per system connector red	maximum 1120 C-Dots per controller maximum 280 C-Dots per XLR output maximum 140 C-Dots per system connector red

\* channel-restricted

\*\* current limited

### Cabling example for System Power Supply 4E with Intelligence C20 and C-Dot

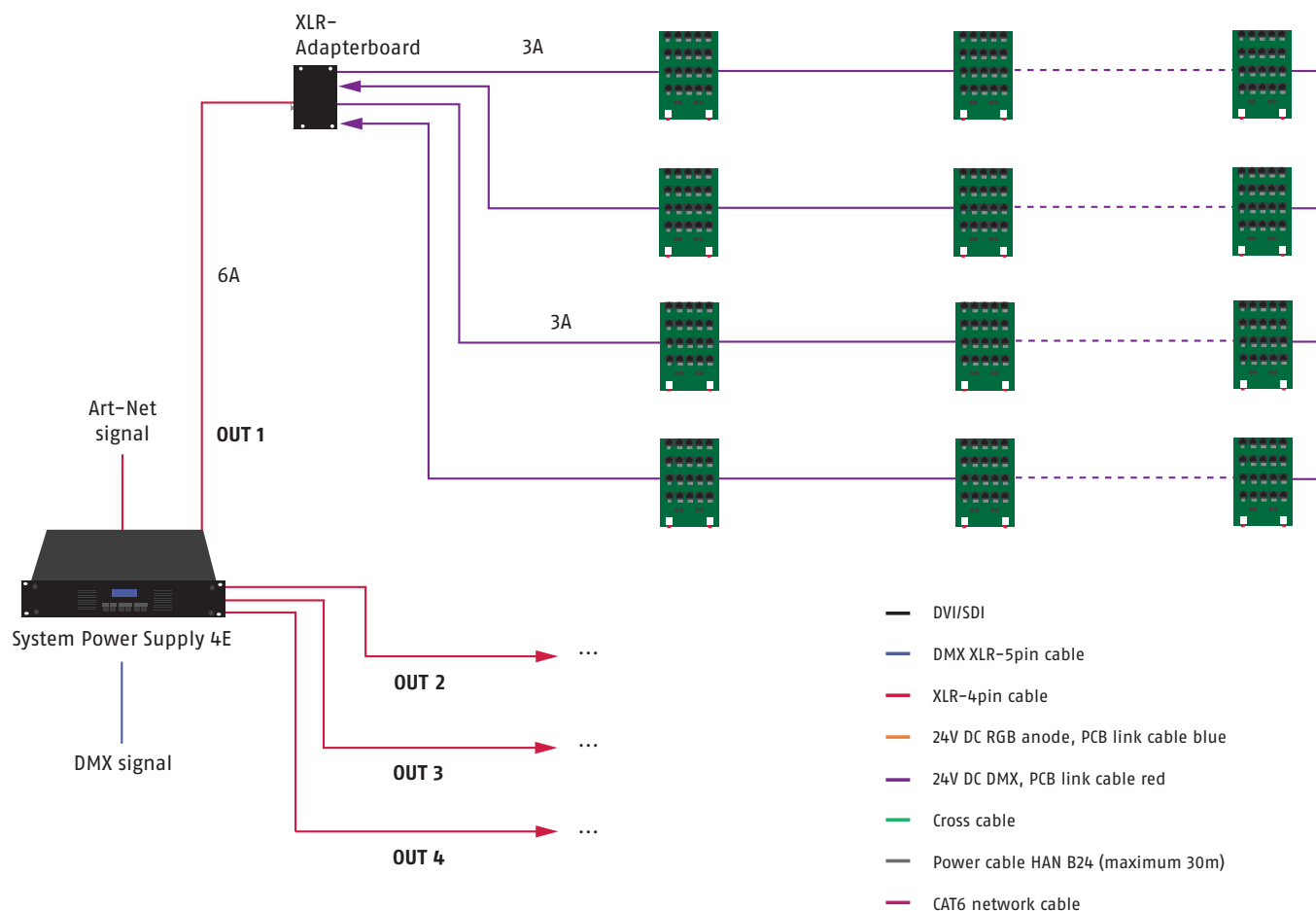

## DPB Pixel-Router





---

### DPB

Intelligence C20	maximum 28 Intelligences C20 per controller maximum 7 Intelligences C20 per output
C-Dot	maximum 560 C-Dots per controller maximum 140 C-Dots per output

---

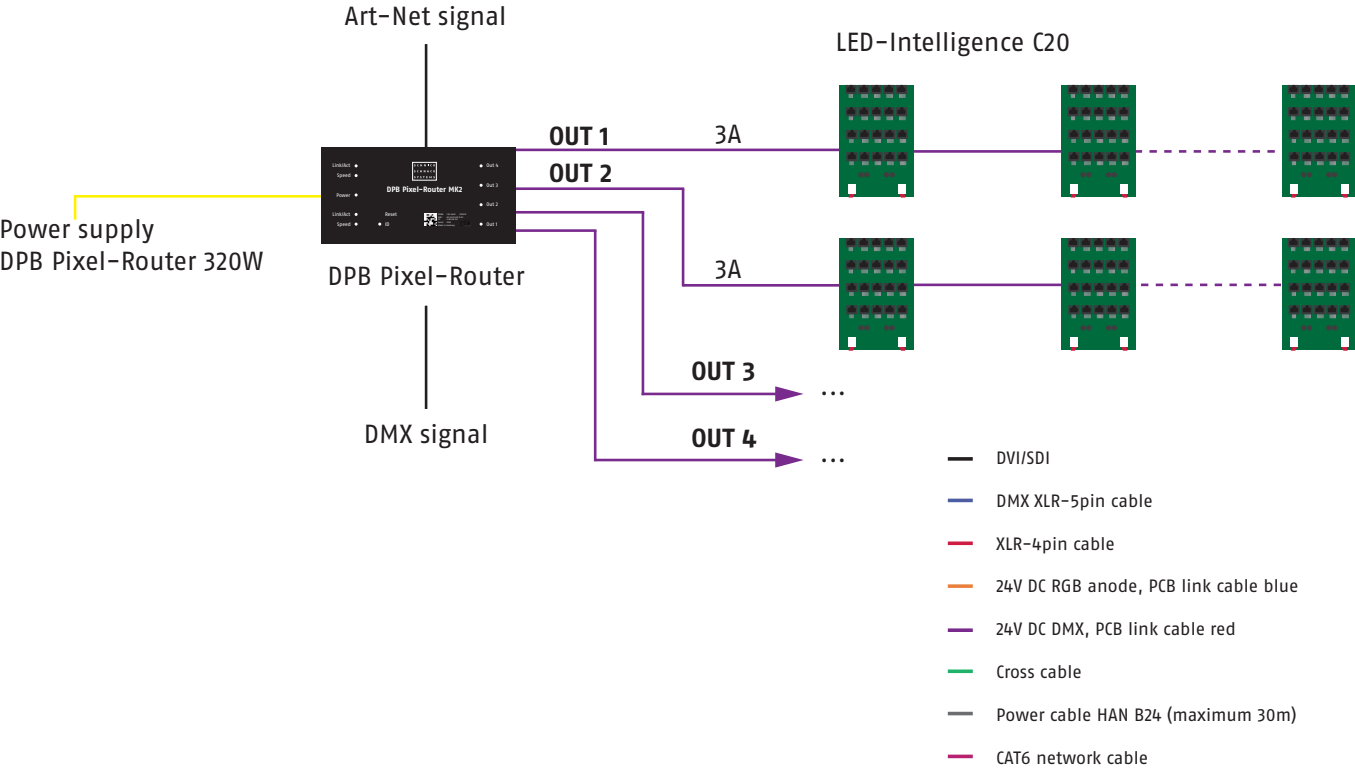
### Cabling example for DPB Pixel-Router and Intelligence C20 with C-Dot



## Sys One

Specific feature: fanless operating



---

### Power Data Out

Output XLR-4pin

Output system connector red (2 universes, wiring example page 15)

---

### DMX 512

maximum 8 Intelligences C20 per controller  
 maximum 160 C-Dots per controller

maximum 14 Intelligences C20 per controller  
 maximum 280 C-Dots per controller  
 maximum 7 Intelligences C20 per system connector red  
 maximum 140 C-Dots per system connector red

---



---

**Please note: connect only one output variable (XLR-4pin or System connector red)!**

**Cabling example for Sys One (XLR-4pin connector) and Intelligence C20 with C-Dot**

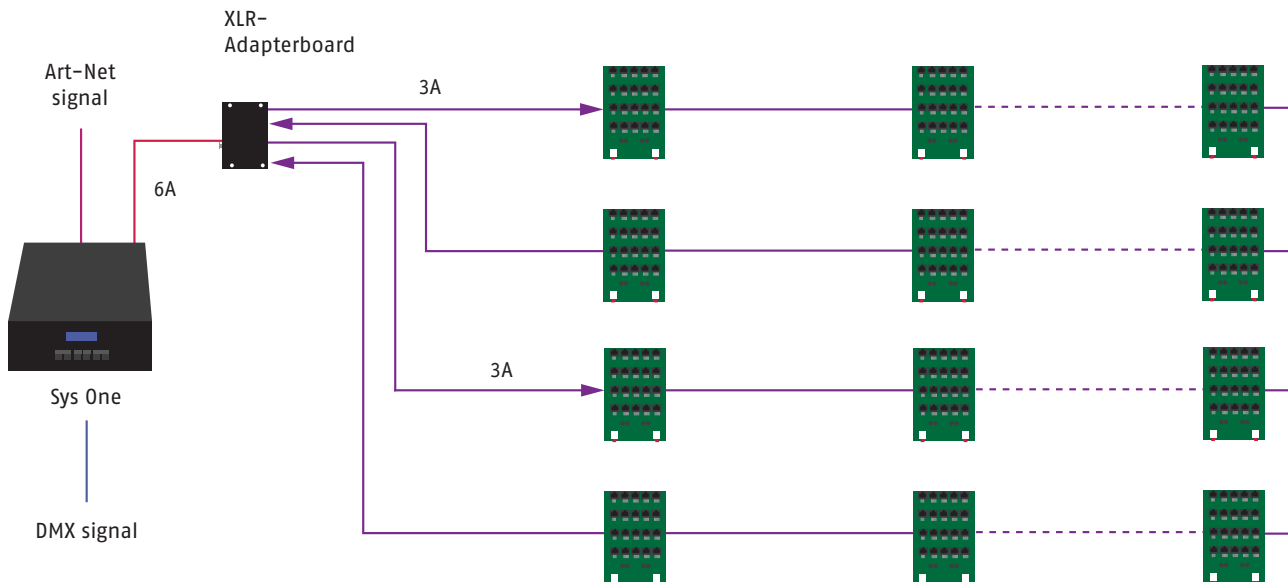

**Cabling example for Sys One (system connector red) with Intelligence C20 and C-Dot**

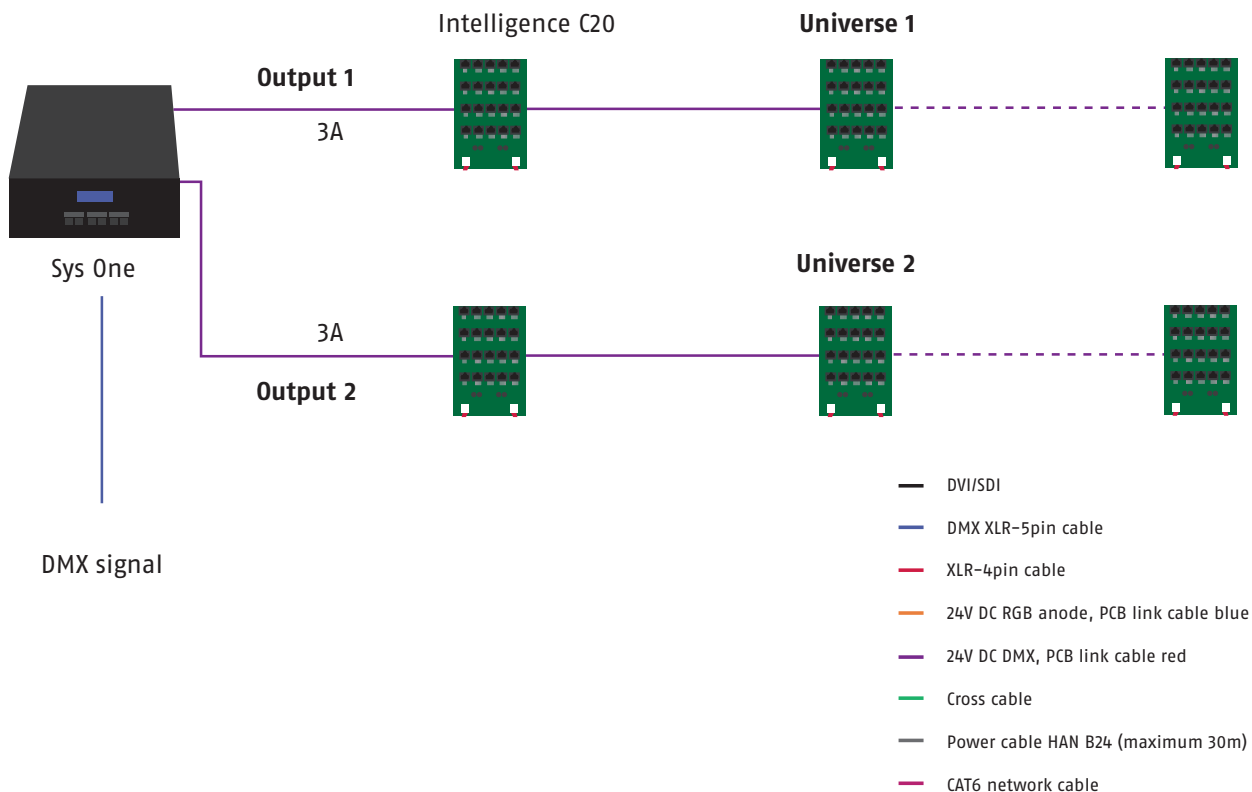

## 70W power supply with DMX



### DMX 512

maximum 7 Intelligences C20 per power supply  
 maximum 140 C-Dots per power supply

## Cabling example for 70W power supply with DMX

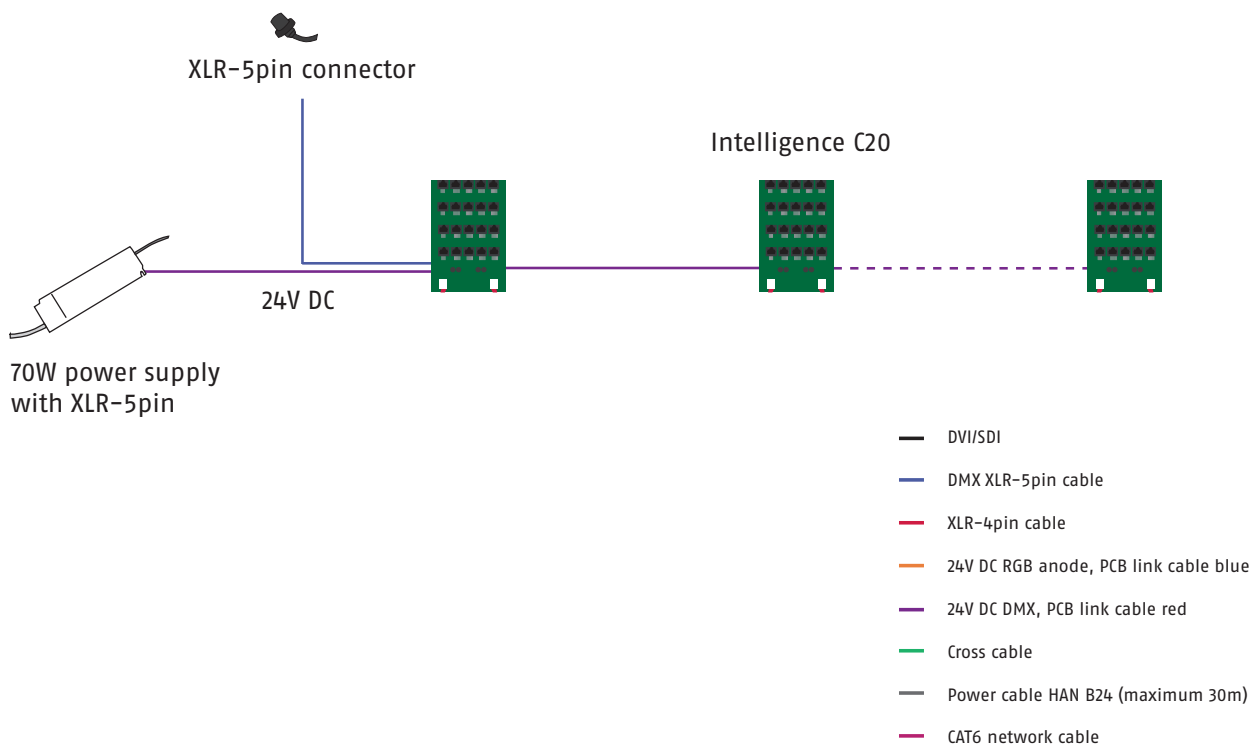



# Order numbers

	Colour	Power ( $I_{max}$ )	Channels	Item number
C-Dot connector output at 90°	RGB	0,015A	3	122.0090
C-Dot connector output at 90° (with 8mm acrylic adapter)	RGB	0,015A	3	122.0190

	Operating voltage	Power (auxiliary power)	Channels	Input	Output	Item number
Intelligence C20 (board)	24V DC	0,4A (0,1A auxiliary power + 60 Channels × 5mA @ 24V)	60	System connector red	RJ 45	203.2010

	Operating voltage	Power ( $I_{max}$ )	Channels	Input	Output	Item number
System Power Supply 4E	110-240V AC	4 × 6A*	4 × 3072 channels (DPB) 4 × 512 channels (DMX)	Ethercon RJ 45 XLR-5pol IN/Trough	4 × XLR-4pin	203.0003
DPB Pixel-Router MK2	24V DC	4 × 3A	4 × 3072 channels	RJ 45	4 × System connector red	203.0021
DPB Pixel-Router POE MK2	24V DC	4 × 3A	4 × 3072 channels	RJ 45	4 × System connector red	203.0022
Sys One	110-240V AC	1 × 6A or 2 × 3A or 2 × (3 × 1A)	1 × 512** or 2 × 512**	XLR-5pol IN/Trough	1 × XLR-4pin 2 × System connector red 2 × System connector blue	203.0007
70W Power Supply (24V DC + DMX)	220-240V AC					204.0152

\* Note: american version only 4 × 4A at 110V

\*\* depending on the output configuration

## ESD warning

Please be aware that electrostatic discharges can destroy LED boards, and our experience shows that this does happen. During assembly, we recommend wearing at least one antistatic wrist strap and avoiding static discharges – such as those that arise when removing protective film or dry cleaning acrylic glass, for example – near LEDs! Antistatic materials should be used when packaging the LED boards. Normal bubble wrap or other plastic bags are not suitable.

For reasons of safety and radio shielding, please only use systems we have approved to provide a power supply for our LED components. All technical information is based on the version at the time of printing.

We reserve the right to make technical specifications in terms of a product improvement without prior notice. Printing – even excerpts – requires the written consent of Schnick-Schnack-Systems GmbH.

---

## **Why Schnick Schnack Systems?**

As installation times become increasingly shorter the complexity of systems simultaneously increases as do the requirements of customers.

We are a supplier who delivers high-quality reliable systems – under tight deadline constraints that are not only quick to install but also simple to operate and service.

## **Schnick-Schnack-Systems GmbH**

Mathias-Brüggen-Straße 79  
50829 Cologne (Germany)

Phone +49 (0) 221/99 2019-0  
Fax +49 (0) 221/16 85 09-73

[info@schnickschnacksystems.com](mailto:info@schnickschnacksystems.com)  
[www.schnickschnacksystems.com](http://www.schnickschnacksystems.com)

© 2017 Schnick-Schnack-Systems GmbH

Version May 2017: All technical data and the weight and dimension information were carefully created – errors reserved. Any colour deviations are printing-related.

We reserve the right to make changes that serve further improvement.