

# LED-Strip C50 MK2.6

Product Sheet

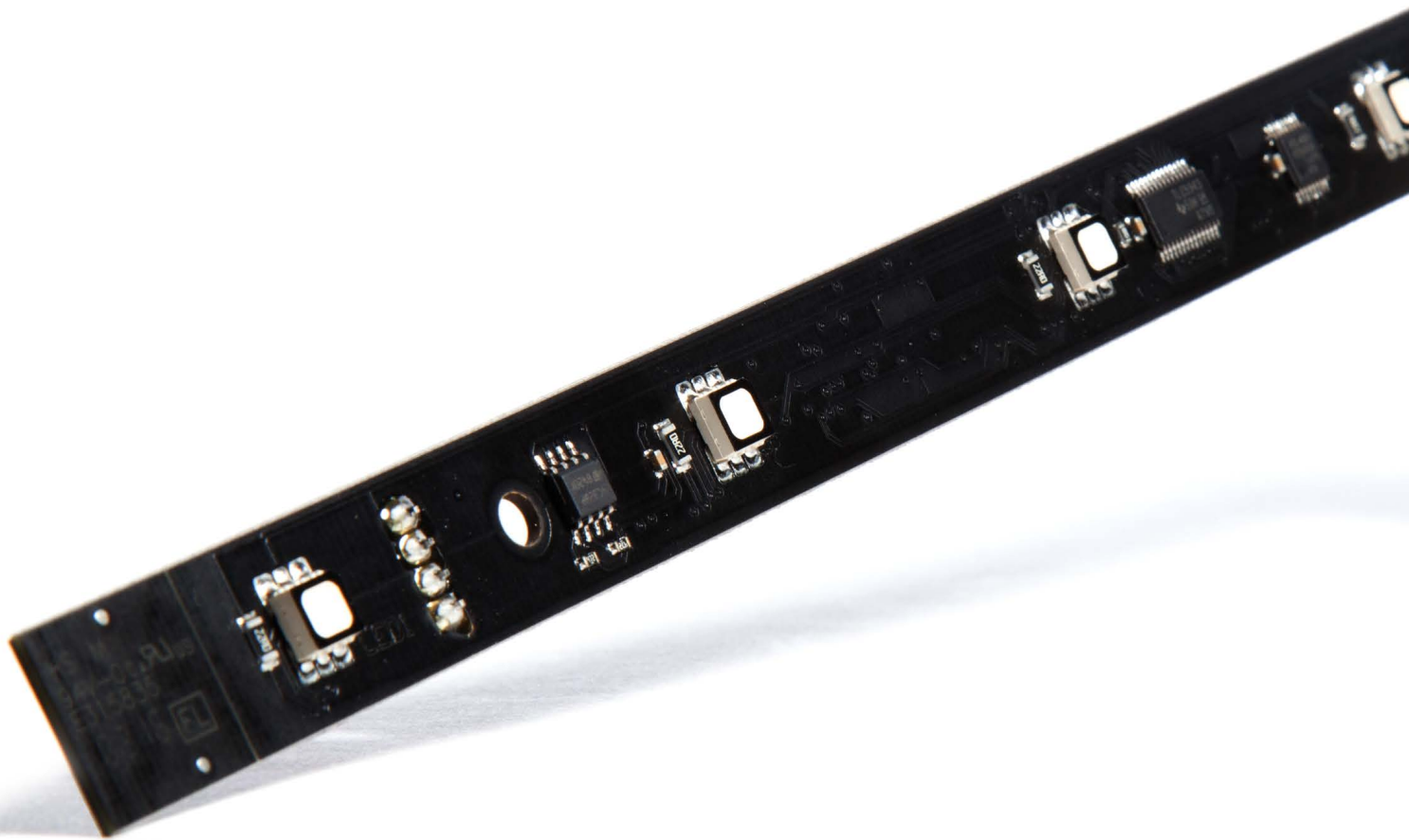

# Introduction

## FEATURES

- Generation 3 compatible
- Automatic Addressing System (Smart Link) – no addressing at the board
- Compatible with other series from Schnick-Schnack-Systems
- Free patch, color change and scroll text control software
- Made in Germany

- Premium quality LEDs
- Individual color calibration of fitted LEDs
- Subsequent calibration possible
- Optimum RGB color mixing in an SMD-component (no colored shadows)
- Wider 115° beam angle
- camera friendly dimmable
- Equal brightness despite different supply-line lengths due to integrated switching regulator
- Enough "headroom" for longer durability

- Direct control with DMX 512-A
- Direct connection to 24V DC

- Pliable, fiberglass reinforced board
- Minimal surface temperature
- Higher contrast due to black lacquered board
- Versatile mounting options

## Use

The Product C-Series LED Strips are equipped with high quality and efficient RGB LEDs. Each LED can be individually controlled and are therefore the ideal LED light source for all uses when edges, surfaces or decorative elements are going to be illuminated with video effects. Whether used for backlighting or as a display, the C-Series LED Strips bring color and movement to walls, floors, counters, light boxes or architectural features enabling the most flexible forms of displays.

## Technology

The LED-Strips C50 MK2.6 come in lengths of 250mm and 500mm in a 50mm grid. These practical dimensions mean the LED-Strips can be adapted to many lighting situations. The LEDs are individually color calibrated and therefore white and pastel tones can be controlled more precisely. The color effect of the LED-Strips is more natural and, unlike with the group controlled RGB Systems, shading and color variation is possible within a line. Due to the arrangement of the LEDs there is no color shift in the horizontal viewing angle when mounted vertically. The LEDs in the C-Series are also dimmable and therefore more camera-friendly. A DMX converter integrated into the board simplifies the cabling and enables a quick system start-up. And, thanks to our Smart Link Technology elaborate addressing of the Strips is no longer necessary.

The C50 MK2.6 LED Strips belong to Generation 3 and in addition to DMX, can also read the Dynamic-Pixel-Bus protocol (DPB). By using the DPB, more LED Strips per output of a system power supply are available. A variable transmission rate enables the best, customized balance of channel count, frame and error rate. When video signals are used, a system-wide synchronization – System Wide Sync – prevents image distortion. The system speed can therefore easily reach the 60fps update rate and switching between DMX and DPB is possible at all times.

The firmware can be upgraded from one central point via the network with the System Power Supply 4E, which also means that future standards or additional developments can be supported. Each Strip sends status information such as temperature, data error rate, input voltage or LED defects back to the control system and therefore enabling a problem-free remote diagnosis.

When using diffusers, the distance needed to create a homogeneous surface depends on the material. There should be at least 8cm from the topside of the LED to the diffuser. The LEDs are mounted with board holders.

## Control

Power is drawn from the System Power Supply 4E, the DPB Pixel-Router or the Sys One – for smaller installations also via an appropriate power supply. Pixel-accurate control of the C-Series LED Strips can be achieved with lighting boards, media servers or with our Pixel-Gate video converter via the Ethernet interface of the System Power Supply 4E.

# Mechanical data

Features	LED-Strip C50-250 MK2.6	LED-Strip C50-500 MK2.6
Length	250mm	500mm
LED-Pitch	50mm	50mm
Number of RGB LEDs	5	10
Pin connection and -colour	System connector red	System connector red
Safety class	IP00	IP00
Weight	19g	33g



LED-Strip C50-250 (front view)



LED-Strip C50-250 (rear view)



LED-Strip C50-500 (front view)



LED-Strip C50-500 (rear view)

# CAD drawing\*

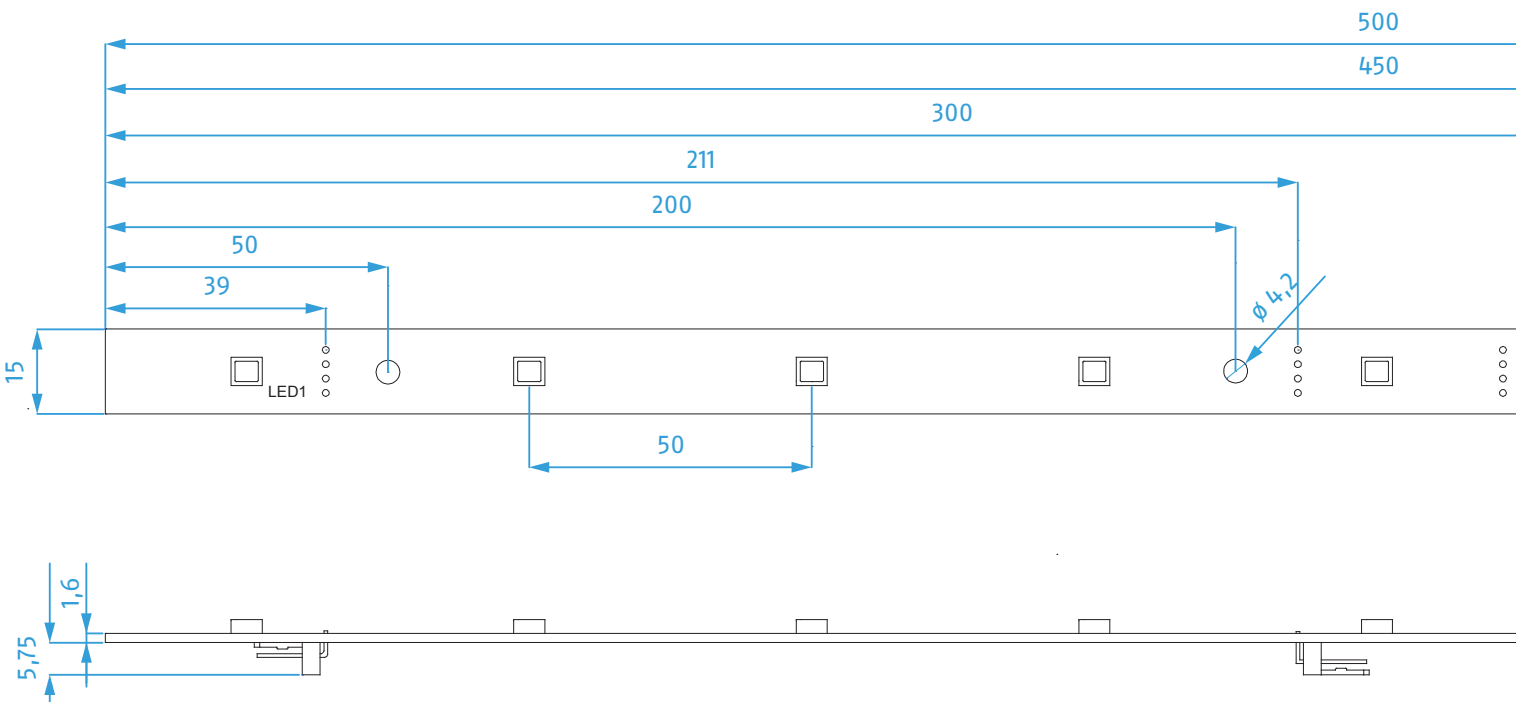
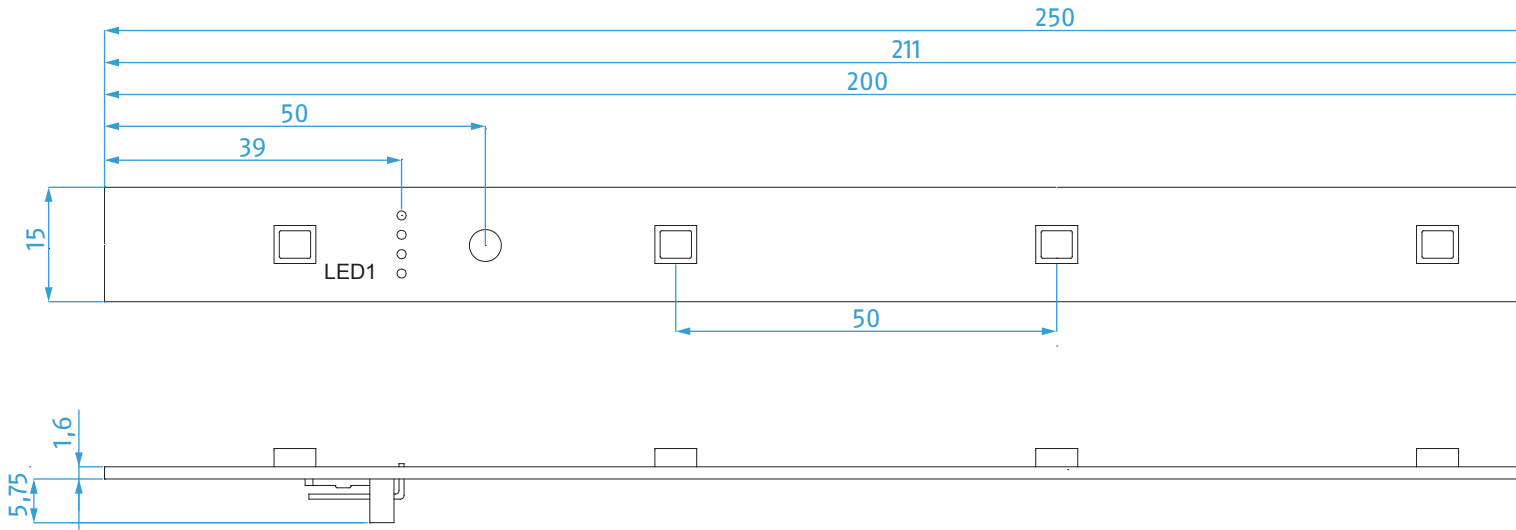

\* without scale / all units in mm

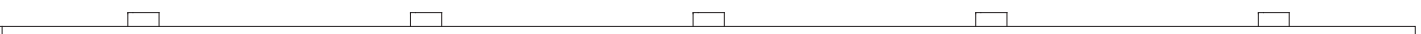
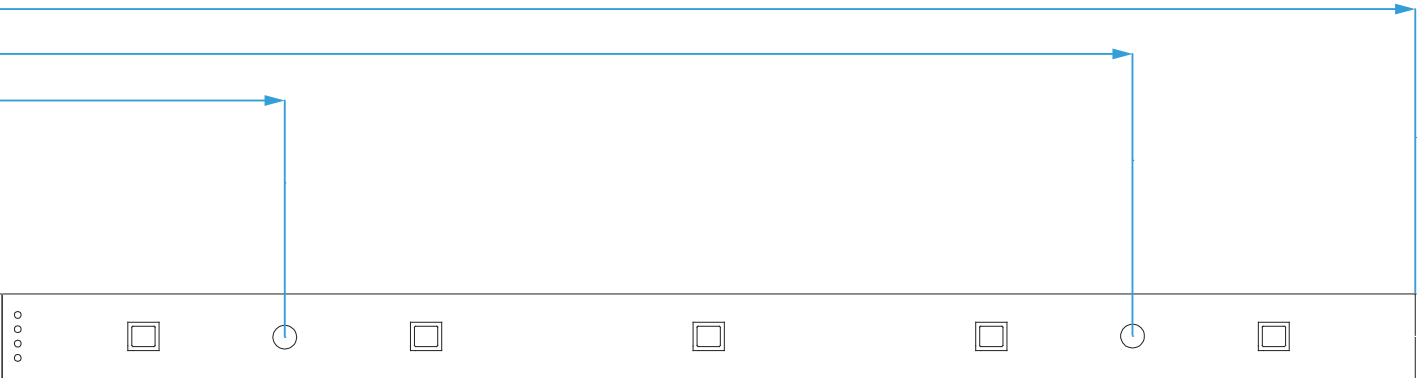
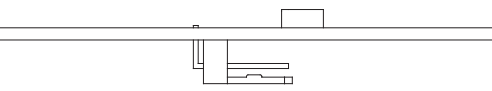
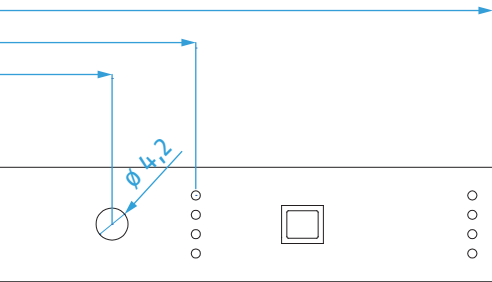

# Optical data

Features	LED-Strip C50-250 MK2.6	LED-Strip C50-500 MK2.6
Colour	RGB	RGB
Emission angle	115°	115°
Lighting current	45lm*	90lm*
Light intensity	12,5cd*	25cd*

## Distance/Lux table

Distance	LED-Strip C50-250 MK2.6	LED-Strip C50-500 MK2.6
0,5m	50lx*	100lx*
1m	12,5lx*	25lx*
2m	3,125lx*	6,25lx*

\* The data provided are measured values. As these values are subject to fluctuations, the actual values of the delivered LEDs may deviate from them. The photometric values apply to full white with RGB = 255.

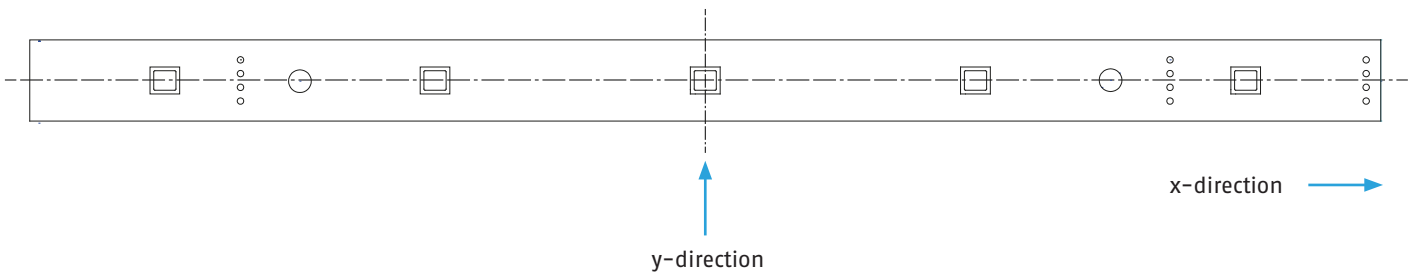

**Light distribution curves, x-direction**

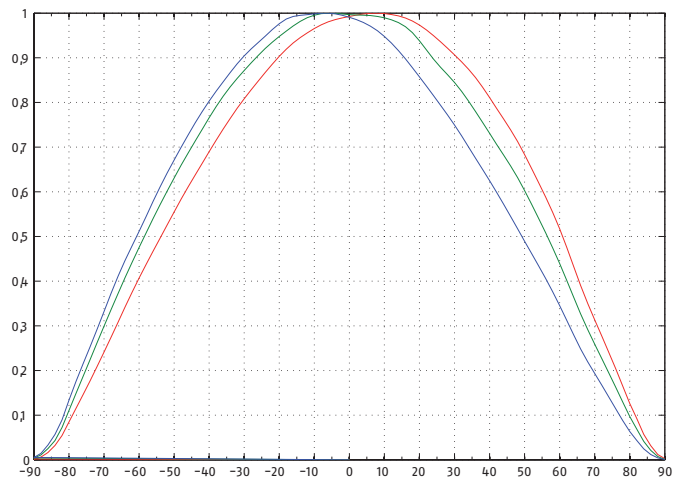
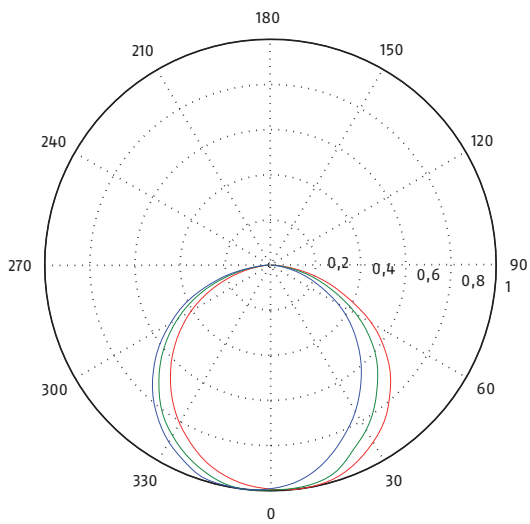

**Light distribution curves, y-direction**

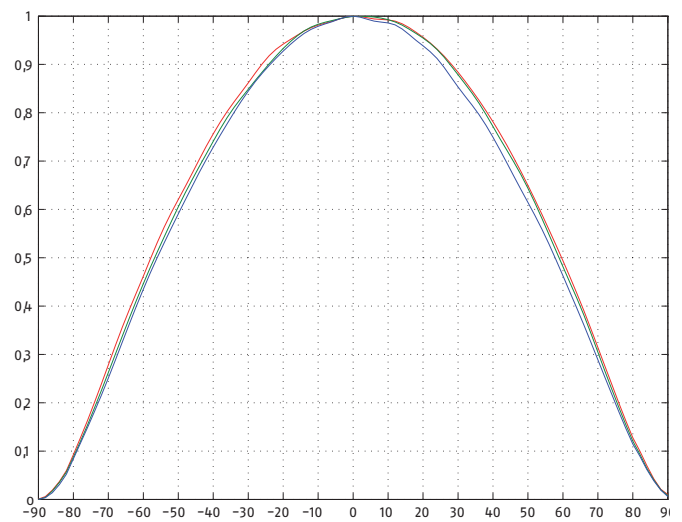
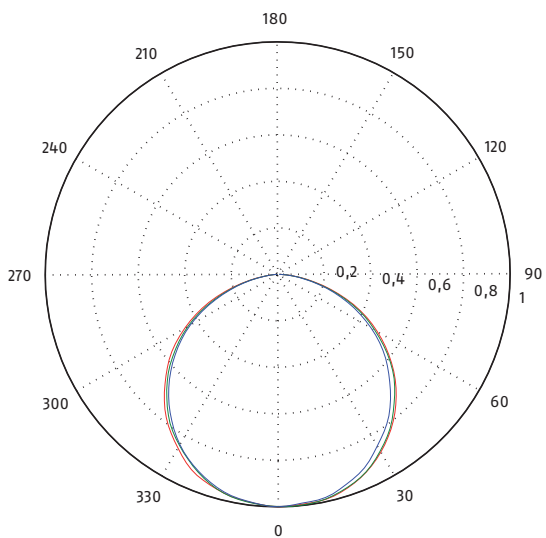

**Gamut diagram**

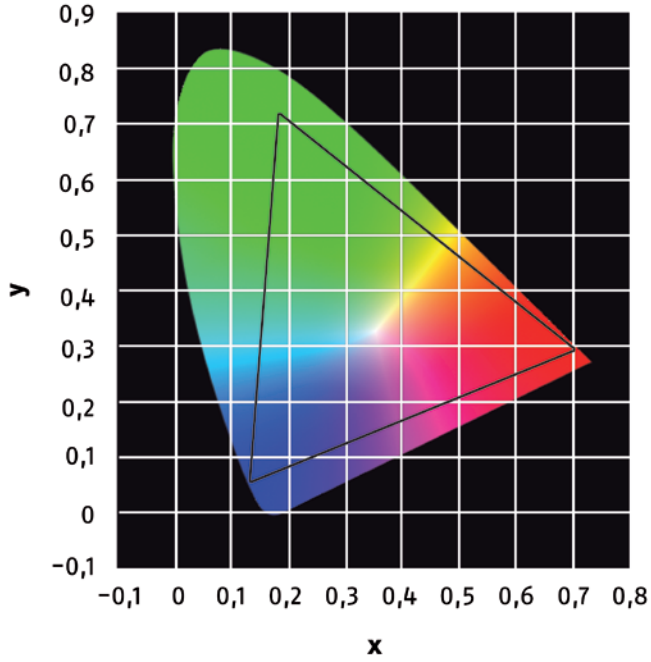

**Spectral distribution**

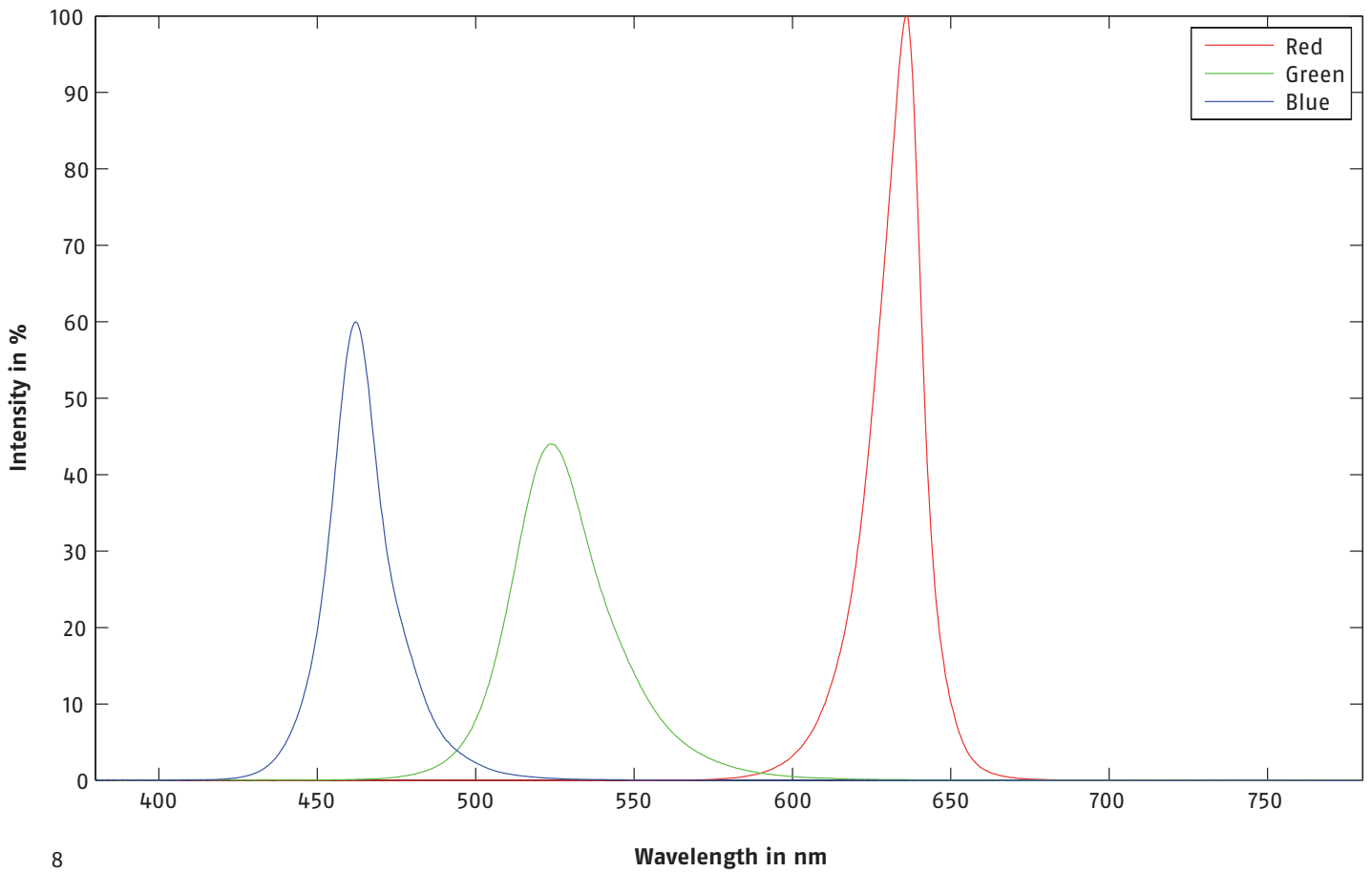



# Mounting

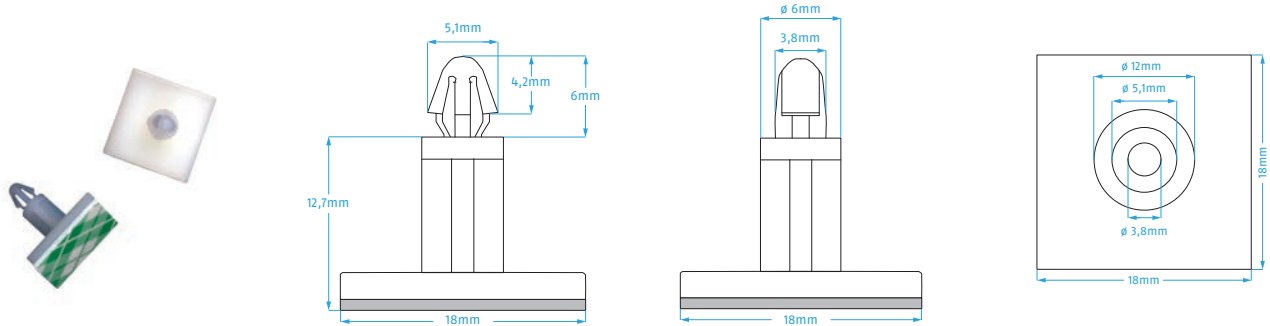

**Description**

PCB holder 12mm, self-adhesive version

**Item number**

802.0002

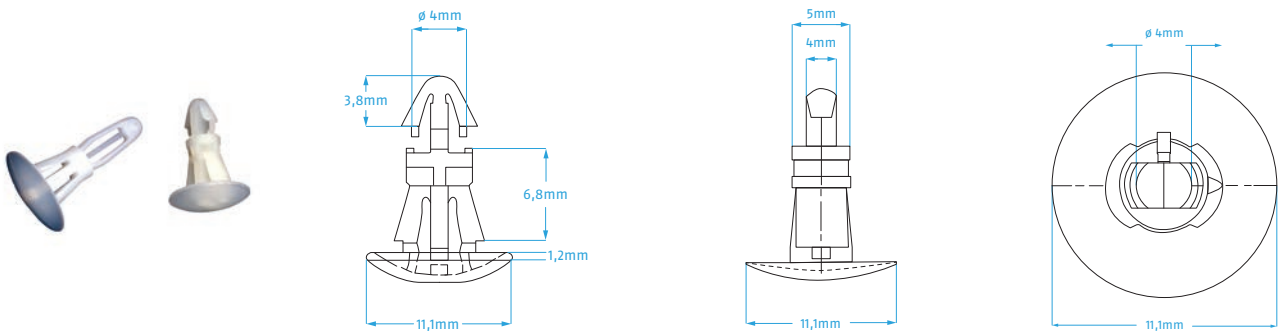

**Description**

PCB holder 6mm, plug-in version (for plates)

**Item number**

802.0003

**Drill hole**

5,4mm

**Material thickness**

1,5-1,6mm

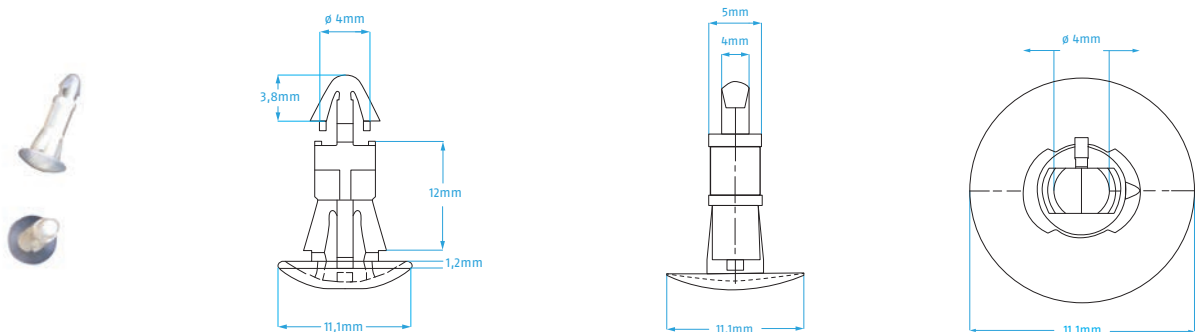

**Description**

PCB holder 12mm, plug-in version (for plates)

**Item number**

802.0004

**Drill hole**

5,4mm

**Material thickness**

1,5-1,6mm

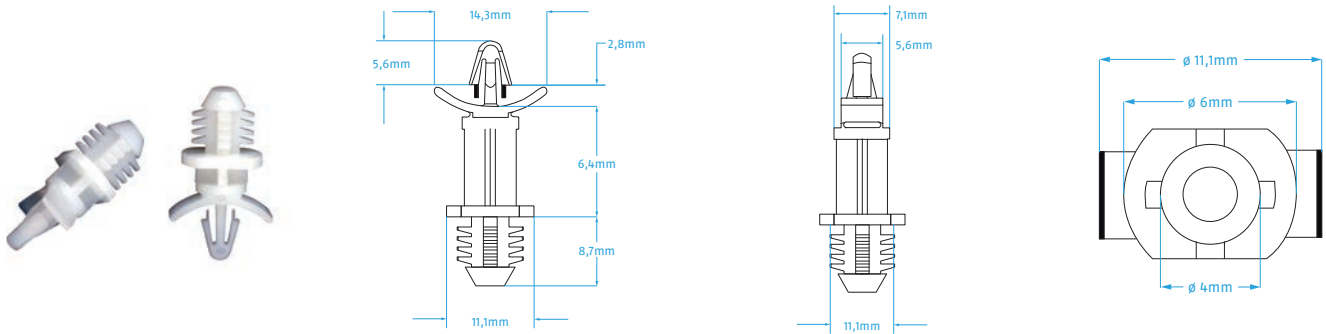

Description	Item number	Drill hole	Material thickness
PCB holder 6mm, drill version (for wood or plastic)	802.0006	7,9mm	minimum 6,4mm

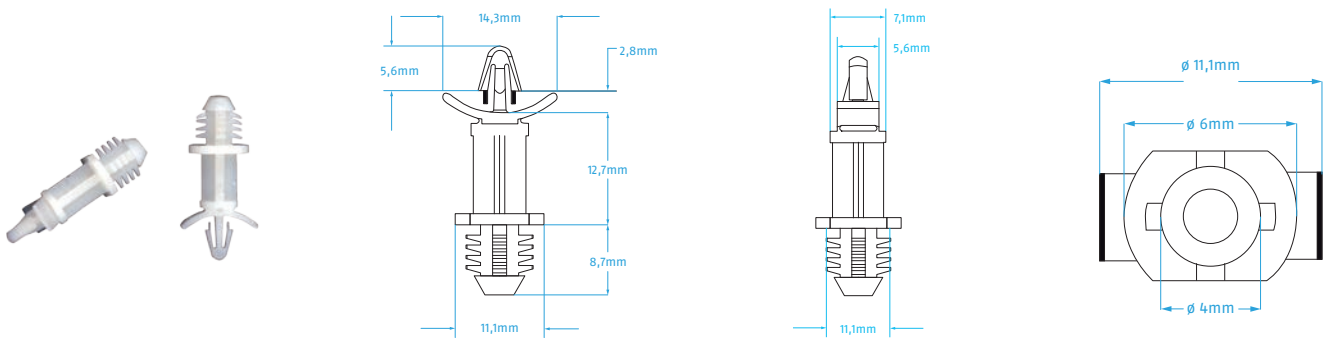

Description	Item number	Drill hole	Material thickness
PCB holder 12mm, drill version (for wood or plastic)	802.0007	7,9mm	minimum 6,4mm

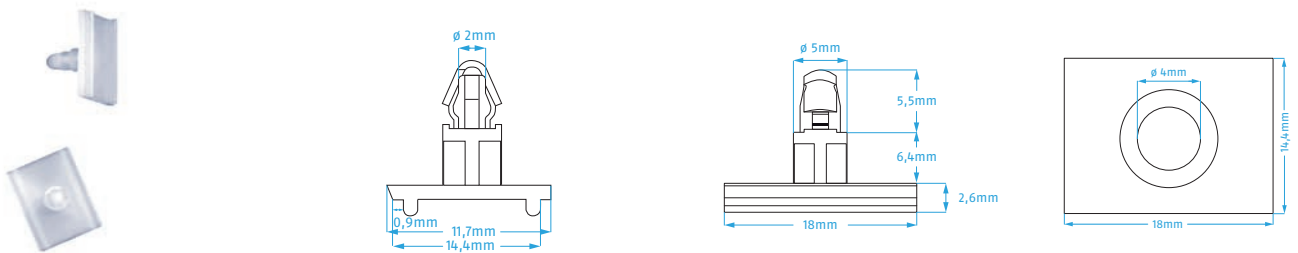

Description	Item number
PCB holder 6mm, plug-in version (for click-profile)	802.0009

# Accessoires

## Cylindrical profiles

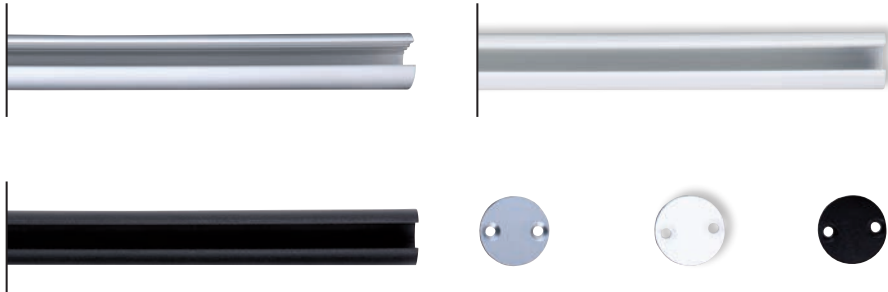

Cylindrical profiles	Item number
Cylindrical profile, 2m, ø 25mm, aluminium anodised	804.2504
Cylindrical profile, 2m, ø 25mm, white	804.2505
Cylindrical profile, 2m, ø 25mm, black	804.2506

Bracket	Item number
Bracket for cylindrical profile (white)	802.0037
Bracket for cylindrical profile (transparent)	802.0038
Bracket for cylindrical profile (black)	802.0039

Covering	Item number
Covering for cylindrical profile 2m, transparent	804.2594

Head ends	Item number
Head end aluminium natural, lasered, 2mm thin, including screws	804.2520
Head end aluminium, rotated, anodised, 12mm width, including screws	804.2541
Head end aluminium, rotated, anodised, 12mm width, with cable outlet, including screws	804.2551
Head end white, lasered, 2mm thin, including screws	804.2522
Head end white, rotated, 12mm width, including screws	804.2542
Head end white, rotated, 12mm width, with cable outlet, including screws	804.2552
Head end black, lasered, 2mm thin, including screws	804.2523
Head end black, rotated, 12mm width, including screws	804.2543
Head end black, rotated, 12mm width, with cable outlet, including screws	804.2553

Special lengths and colours available upon request. For special colours please provide relevant RAL-information.

## Rectangular profiles



### Rectangular profiles

	Item number
Rectangular profile, 2m, 24mm × 30mm (W × H), aluminium anodised	804.2401
Rectangular profile, 2m, 24mm × 30mm, aluminium anodised, in pack of ten	804.2411
Rectangular profile, 2m, 24mm × 30mm (W × H), white	804.2402
Rectangular profile, 2m, 24mm × 30mm (W × H), white, in pack of ten	804.2412
Rectangular profile, 2m, 24mm × 30mm (W × H), black	804.2403
Rectangular profile, 2m, 24mm × 30mm (W × H), black, in pack of ten	804.2413

### Brackets

	Item number
Bracket for rectangular profile, 2m, plastic, black	802.0040
Bracket for rectangular profile, 2m, plastic, black, in pack of ten	802.0041

### Click profile

	Item number
Click eachfile for rectangular profile, 2m, transparent	804.2492
Click eachfile for rectangular profile, 2m, in pack of ten	804.2493

### Head ends

	Item number
Head end aluminium anodised, 6mm, including screws	804.2431
Head end aluminium anodised, 12mm, including screws	804.2441
Head end white, lacquered, 6mm, including screws	804.2432
Head end white, lacquered, 12mm, including screws	804.2442
Head end black, lacquered, 6mm, including screws	804.2433
Head end black, lacquered, 12mm, including screws	804.2443

Special lengths and colours available upon request. For special colours please provide relevant RAL-information.

# Electrical data

Features	LED-Strip C50-250 MK2.6	LED-Strip C50-500 MK2.6
Voltage	24V	24V
Current ( $I_{max}$ )	0,15A	0,3A

# Pin Connection

## Systemconnector red

1	■	GND
2	■	DMX -
3	■	DMX +
4	■	24 V

# Control options for LED-Strip C50 MK2.6

## System Power Supply 4E



## LED-Strip C50-250 MK2.6

### DMX 512\*

maximum 136 LED-Strips per controller  
 maximum 34 LED-Strips per XLR output  
 maximum 20 LED-Strips per system connector red

### DPB\*\*

maximum 160 LED-Strips per controller  
 maximum 40 LED-Strips per XLR output  
 maximum 20 LED-Strips per system connector red

## LED-Strip C50-500 MK2.6

### DMX 512\*

maximum 68 LED-Strips per controller  
 maximum 17 LED-Strips per XLR output  
 maximum 10 LED-Strips per system connector red

### DPB\*\*

maximum 80 LED-Strips per controller  
 maximum 20 LED-Strips per XLR output  
 maximum 10 LED-Strips per system connector red

\*channel-restricted

\*\*current limited

### Cabling example for System Power Supply 4E with LED-Strip C50 MK2.6

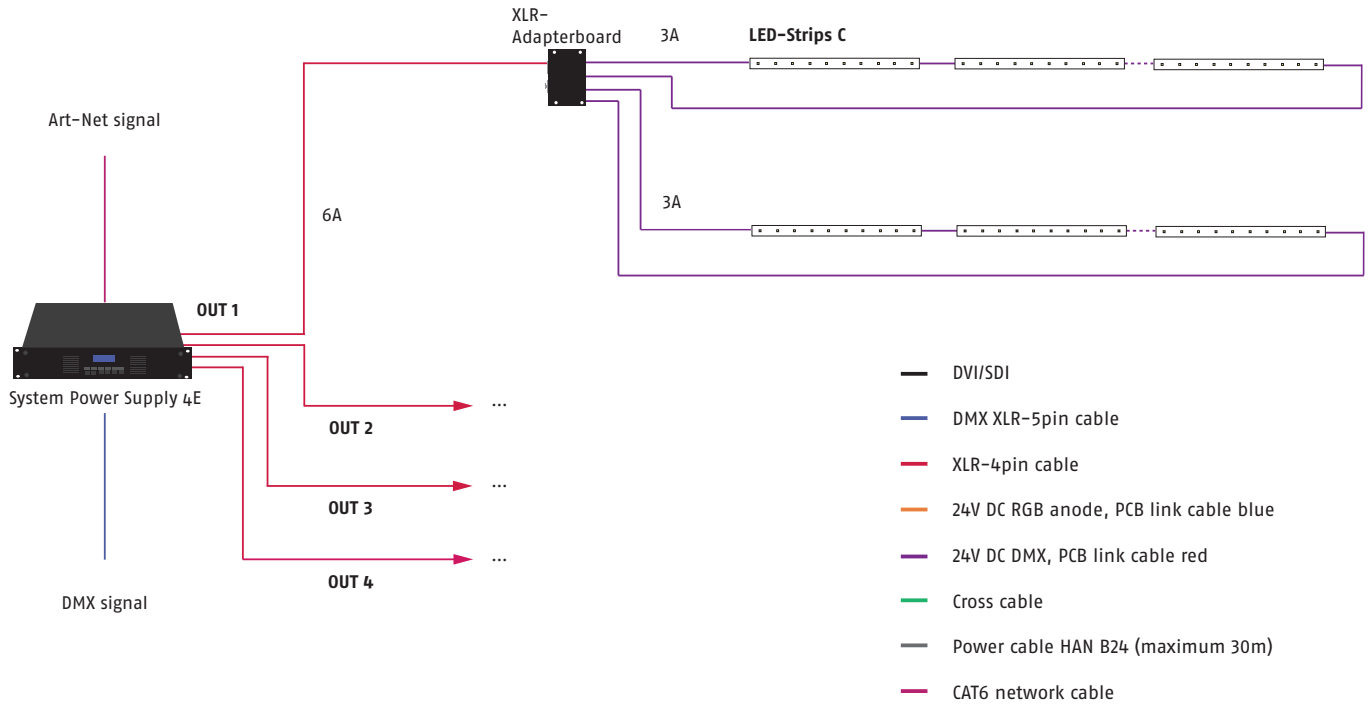

## DPB Pixel-Router



---

### LED-Strip C50-250 MK2.6

maximum 80 LED-Strips per controller  
maximum 20 LED-Strips per output

---

### LED-Strip C50-500 MK2.6

maximum 40 LED-Strips per controller  
maximum 10 LED-Strips per output

---



### Cabling example for DPB Pixel-Router with LED-Strips C50 MK2.6

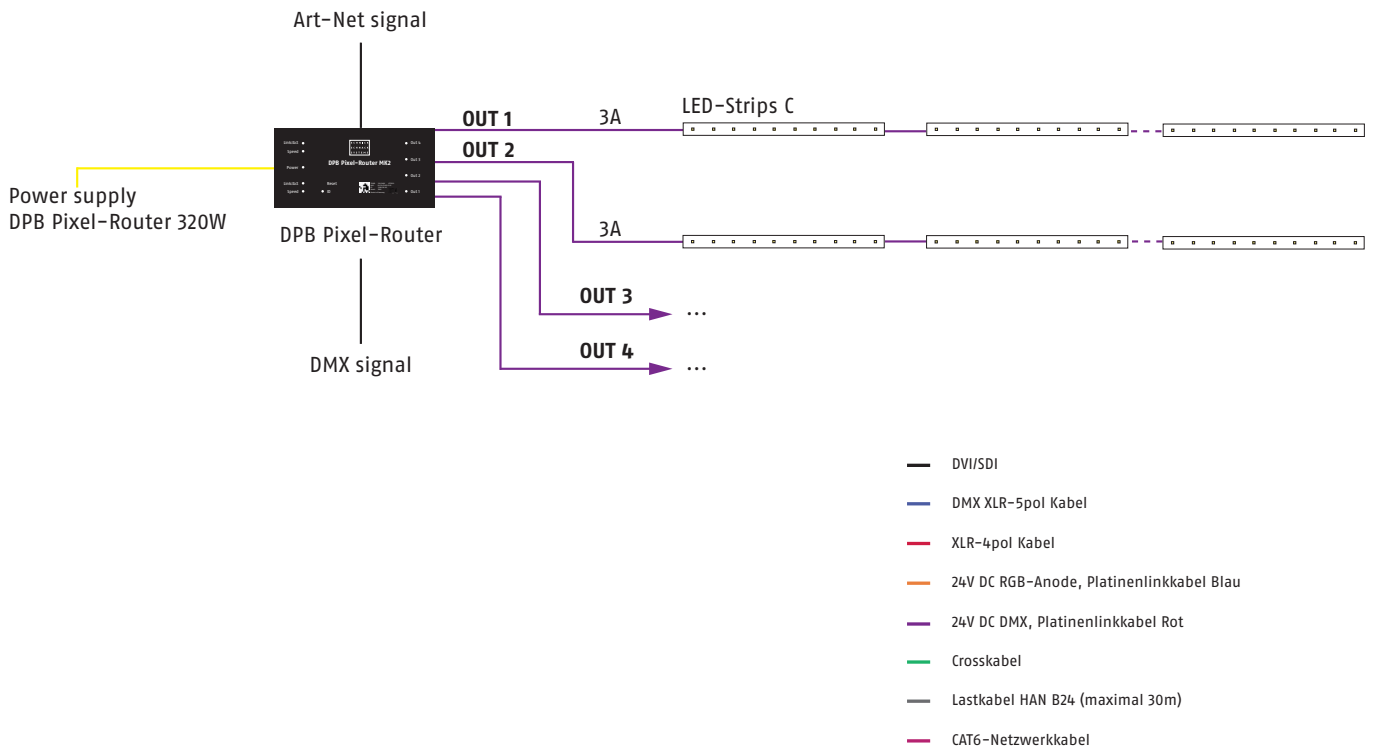

## Sys One

Specific feature: fanless operating



### LED-Strip C50-250 MK2.6

Power Data Out	DMX 512
Output XLR-4pin	maximum 34 LED-Strips per controller
Output system connector red (2 universes, wiring example page 19)	maximum 40 LED-Strips per controller maximum 20 LED-Strips per system connector red

### LED-Strip C50-500 MK2.6

Power Data Out	DMX 512
Output XLR-4pin	maximum 17 LED-Strips per controller
Output system connector red (2 universes, wiring example page 19)	maximum 20 LED-Strips per controller maximum 10 LED-Strips per system connector red

**Please note: connect only one output variable (XLR-4pin or System connector red)!**

### Cabling example for Sys One (XLR-4pin connector) with LED-Strips C50

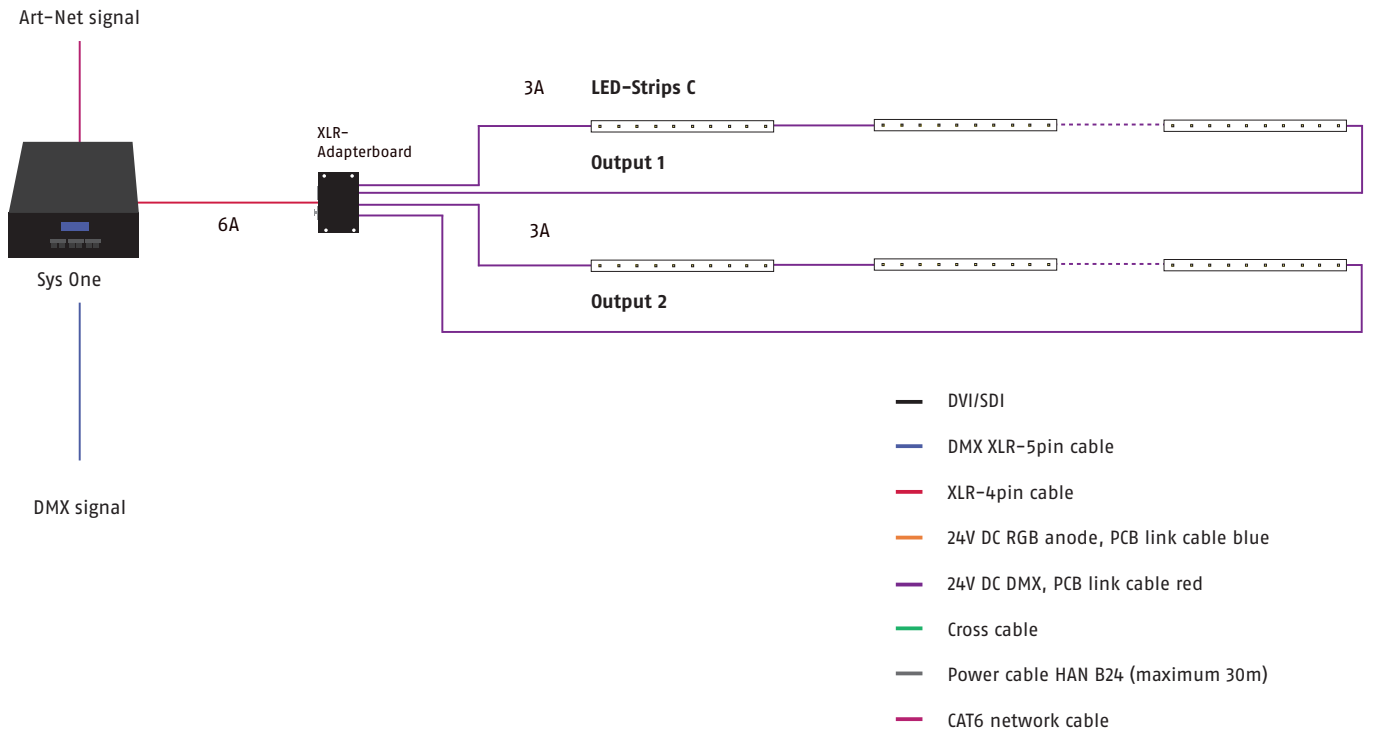

### Cabling example for Sys One (System connector red) with LED-Strips C50

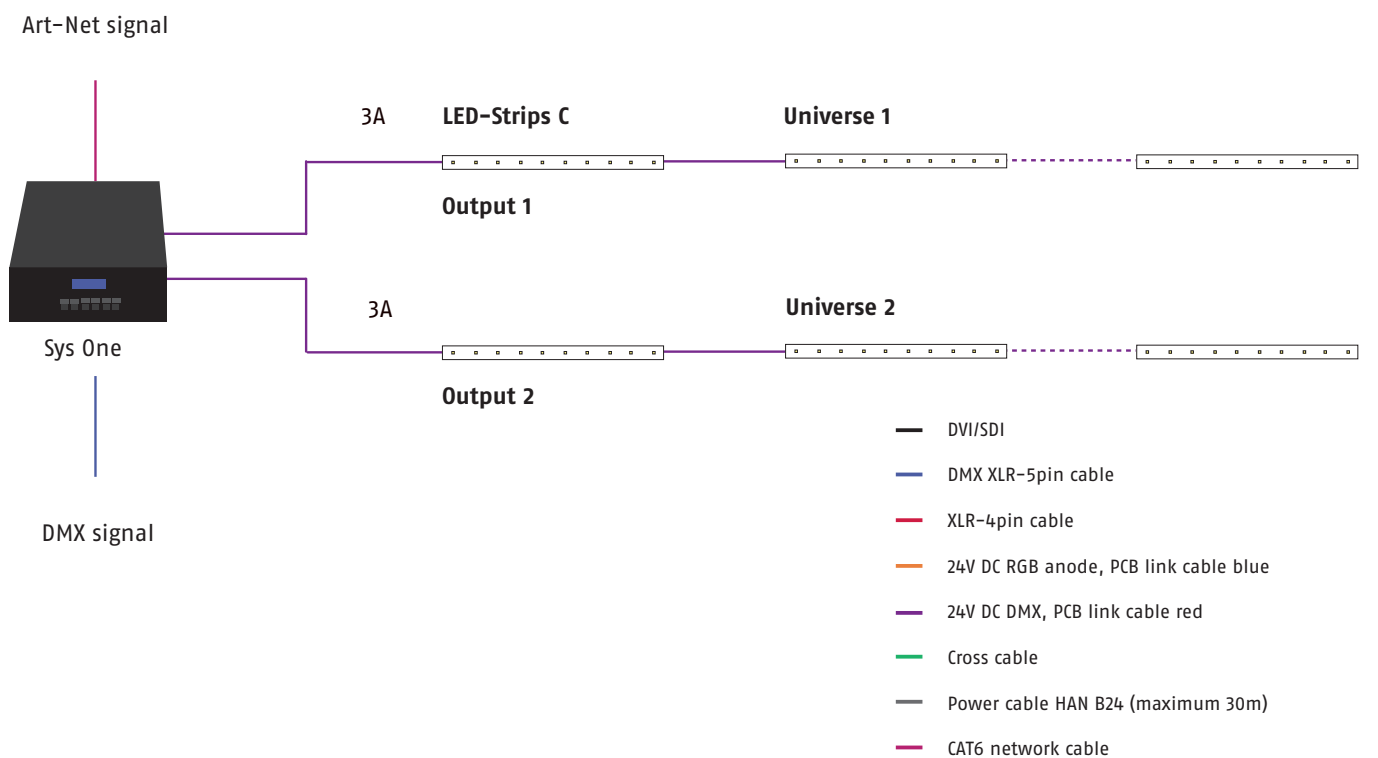

### 70W power supply with DMX



**LED-Strip C50-250 MK2.6**  
 maximum 20 LED-Strips per power supply

**LED-Strip C50-500 MK2.6**  
 maximum 10 LED-Strips per power supply

### Cabling example for 70W power supply with DMX

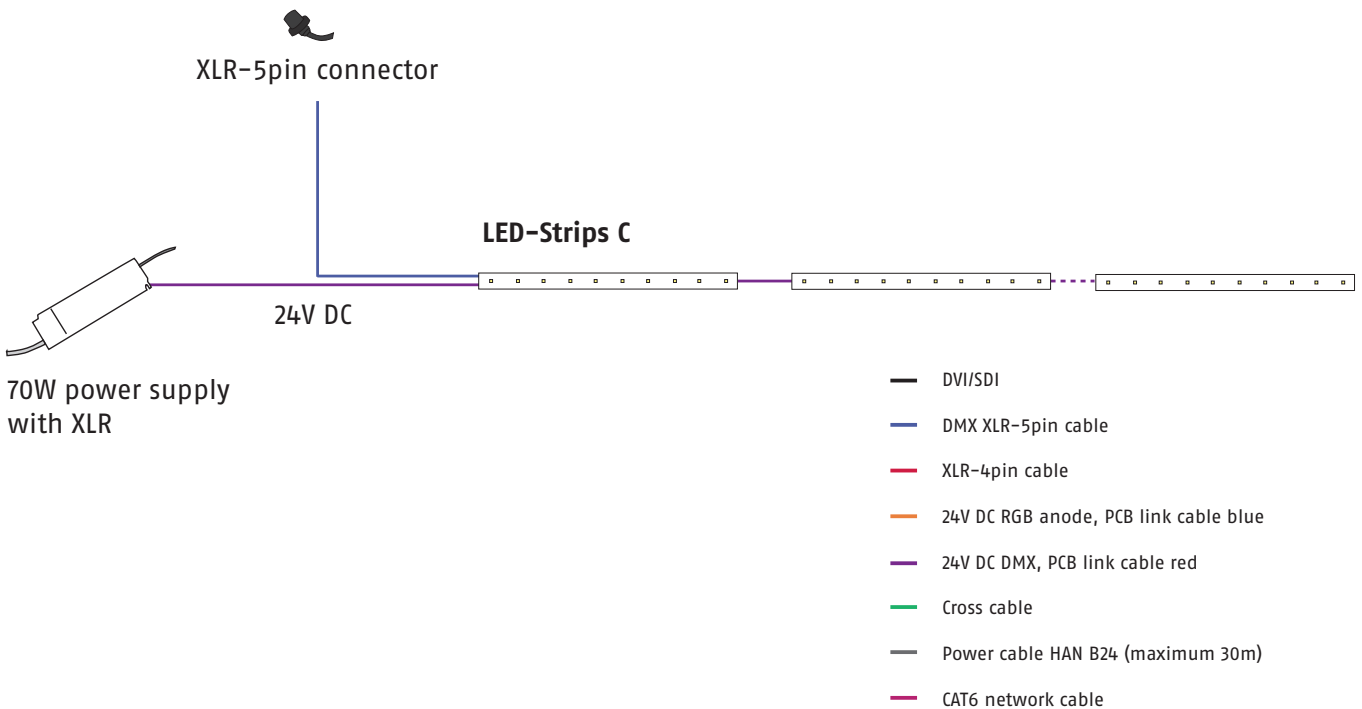

# Order numbers

	Colour	LED-Pitch	Length	Current ( $I_{max}$ )	Channels	Connection	Item number
LED-Strip C50-250 MK2.6	RGB	50mm	250mm	0,15A	15	System connector red	102.5025
LED-Strip C50-500 MK2.6	RGB	50mm	500mm	0,30A	30	System connector red	102.5050

	Operating voltage	Power ( $I_{max}$ )	Channels	Input	Output	Item number
System Power Supply 4E	110-240V AC	4 × 6A*	4 × 3072 channels (DPB) 4 × 512 channels (DMX)	Ethercon RJ 45 XLR-5pol IN/Trough	4 × XLR-4pin	203.0003
DPB Pixel-Router MK2	24V DC	4 × 3A	4 × 3072 channels	RJ 45	4 × System connector red	203.0021
DPB Pixel-Router POE MK2	24V DC	4 × 3A	4 × 3072 channels	RJ 45	4 × System connector red	203.0022
Sys One	110-240V AC	1 × 6A or 2 × 3A or 2 × (3 × 1A)	1 × 512** or 2 × 512**	XLR-5pol IN/Trough	1 × XLR-4pin 2 × System connector red 2 × System connector blue	203.0007

\* Note: american version only 4 × 4A at 110V

\*\* depending on the output configuration

## ESD warning

Please be aware that electrostatic discharges can destroy LED boards, and our experience shows that this does happen. During assembly, we recommend wearing at least one antistatic wrist strap and avoiding static discharges – such as those that arise when removing protective film or dry cleaning acrylic glass, for example – near LEDs! Antistatic materials should be used when packaging the LED boards. Normal bubble wrap or other plastic bags are not suitable.

For reasons of safety and radio shielding, please only use systems we have approved to provide a power supply for our LED components. All technical information is based on the version at the time of printing.

We reserve the right to make technical specifications in terms of a product improvement without prior notice. Printing – even excerpts – requires the written consent of Schnick-Schnack-Systems GmbH.

---

## **Why Schnick Schnack Systems?**

As installation times become increasingly shorter the complexity of systems simultaneously increases as do the requirements of customers.

We are a supplier who delivers high-quality reliable systems – under tight deadline constraints that are not only quick to install but also simple to operate and service.

## **Schnick-Schnack-Systems GmbH**

Mathias-Brüggen-Straße 79  
50829 Cologne (Germany)

Phone +49 (0) 221/99 2019-0  
Fax +49 (0) 221/16 85 09-73

[info@schnickschnacksystems.com](mailto:info@schnickschnacksystems.com)  
[www.schnickschnacksystems.com](http://www.schnickschnacksystems.com)

© 2017 Schnick-Schnack-Systems GmbH

Version October 2017: All technical data and the weight and dimension information were carefully created – errors reserved. Any colour deviations are printing-related.

We reserve the right to make changes that serve further improvement.