

LED-Tile C25 MK2.6

Product Sheet

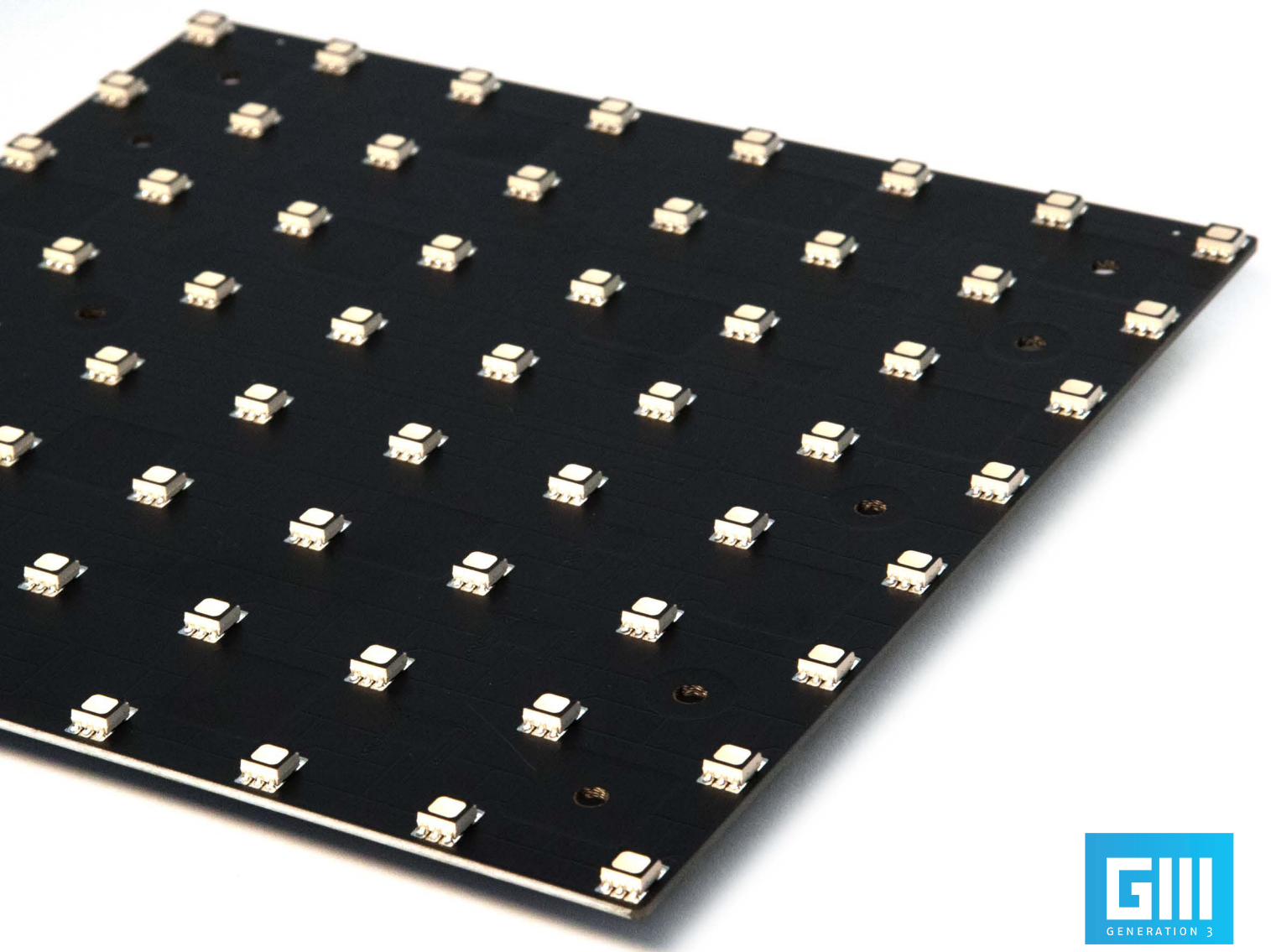

Introduction

FEATURES

- **Generation 3 compatible**
- **Automatic Addressing System (Smart Link) – no addressing at the board**
- **Automatic switching between DMX and DPB protocol**
- **Optional bidirectional DPB protocol for feedback about temperature, voltage, etc. (Easy Feedback)**
- **Compatible with other series from Schnick-Schnack-Systems**
- **Free patch, color change and scroll text control software**
- **Made in Germany**

- **Premium quality LEDs**
- **Individual color calibration of fitted LEDs**
- **Subsequent calibration possible**
- **Optimum RGB color mixing in an SMD-component (no colored shadows)**
- **Wider 115° beam angle**
- **camera friendly dimmable**
- **Equal brightness despite different supply-line lengths due to integrated switching regulator**
- **Enough "headroom" for longer durability**

- **Direct control with DMX 512-A**
- **Direct connection to 24V DC**

- **Minimal surface temperature**
- **Higher contrast due to black lacquered board**
- **Versatile mounting options**

Use

The C Series LED Tiles are equipped with premium quality, efficient RGB LEDs. Each LED can be individually controlled and are therefore the ideal LED light source to illuminate dynamic surfaces and structures or for large-scale video effects. Whether used for backlighting or as a display, the C Series LED Tiles are small multi-media elements. They bring walls, floors, counters, light boxes and other decorative elements to life with movement and color. Large surface video effects can be achieved with a matrix grid.

Technology

The C25 MK2.6 LED Tiles backlight a 200mm × 200mm surface with 64 LEDs. These practical dimensions enable the LED Tiles to be adapted to many lighting situations. Each LED can be individually color calibrated so white and pastel shades can be controlled more precisely. The color effect is more natural and, unlike with the group controlled RGB systems, shading and color variation are possible within a line. Due to the arrangement of the LEDs, there is no color shift in the horizontal viewing angle when mounted vertically. What's more, the C Series LED Tiles are dimmable and therefore more camera-friendly. An integrated DMX converter on the board enables easy wiring and a quick system start up. Thanks to our Smart Link Technology, elaborate addressing of the tiles is eliminated.

The C25 MK2.6 LED Tiles belong to Generation 3 and in addition to DMX, can also read the Dynamic-Pixel-Bus protocol (DPB). By using the DPB, 5 × more LED Tiles per output of a system power supply are available – up to 3,072 channels. A variable transmission rate enables the best, customized balance of channel count, frame and error rate. When video signals are used, a system-wide synchronization prevents image distortion. The system speed can therefore easily reach the 60fps update rate and switching between DMX and DPB is possible at all times.

The tile firmware can be updated from a central point via the network with the System Power Supply 4E, which also means that future standards or developments can be supported. Each tile sends status information such as temperature, data error rates, input voltage or LED defects back to the control system therefore enabling a problem-free diagnosis.

When using diffusers, the distance needed to create a homogeneous surface depends on the material. There should be at least 5cm from the topside of the LED to the diffuser. The LEDs are mounted with board holders.

Control

The System Power Supply 4E or the DPB Pixel-Router is used for both power supply and addressing. Pixel-accurate control of the C Series LED Tiles can be achieved with lighting boards, media servers, with our Pixel-Gate video converter via the Ethernet interface of the System Power Supply 4E as well as with DVI or SDI video signals.

Mechanical data

Features	LED-Tile C25 MK2.6
Backlighted area	200mm × 200mm
Dimensions	184mm × 186mm
LED-Pitch	25mm
Number of RGB LEDs	64
Pin connection and -colour	System connector red
Safety class	IP00
Weight	163g

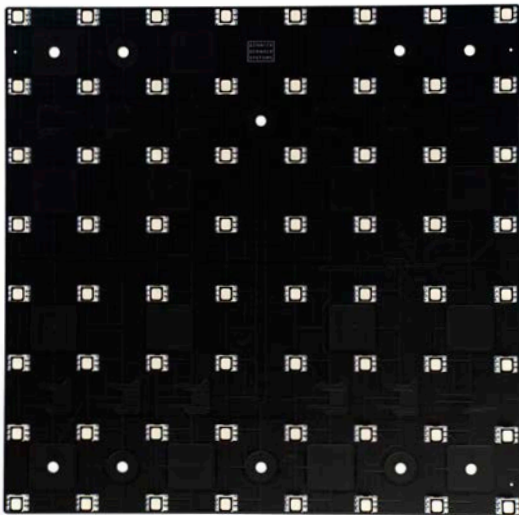

LED-Tile C25 MK2.6 (front view)

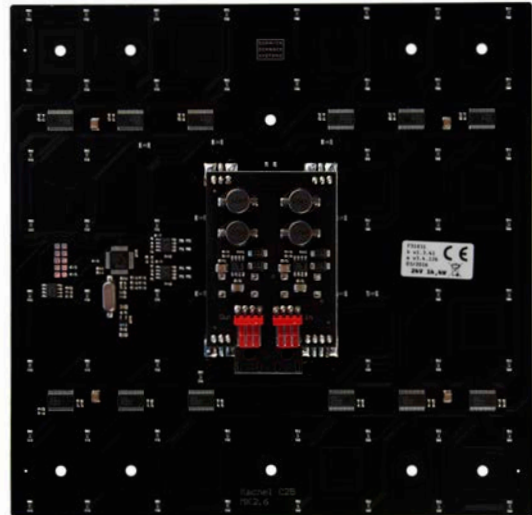

LED-Tile C25 MK2.6 (rear view)

CAD drawing*

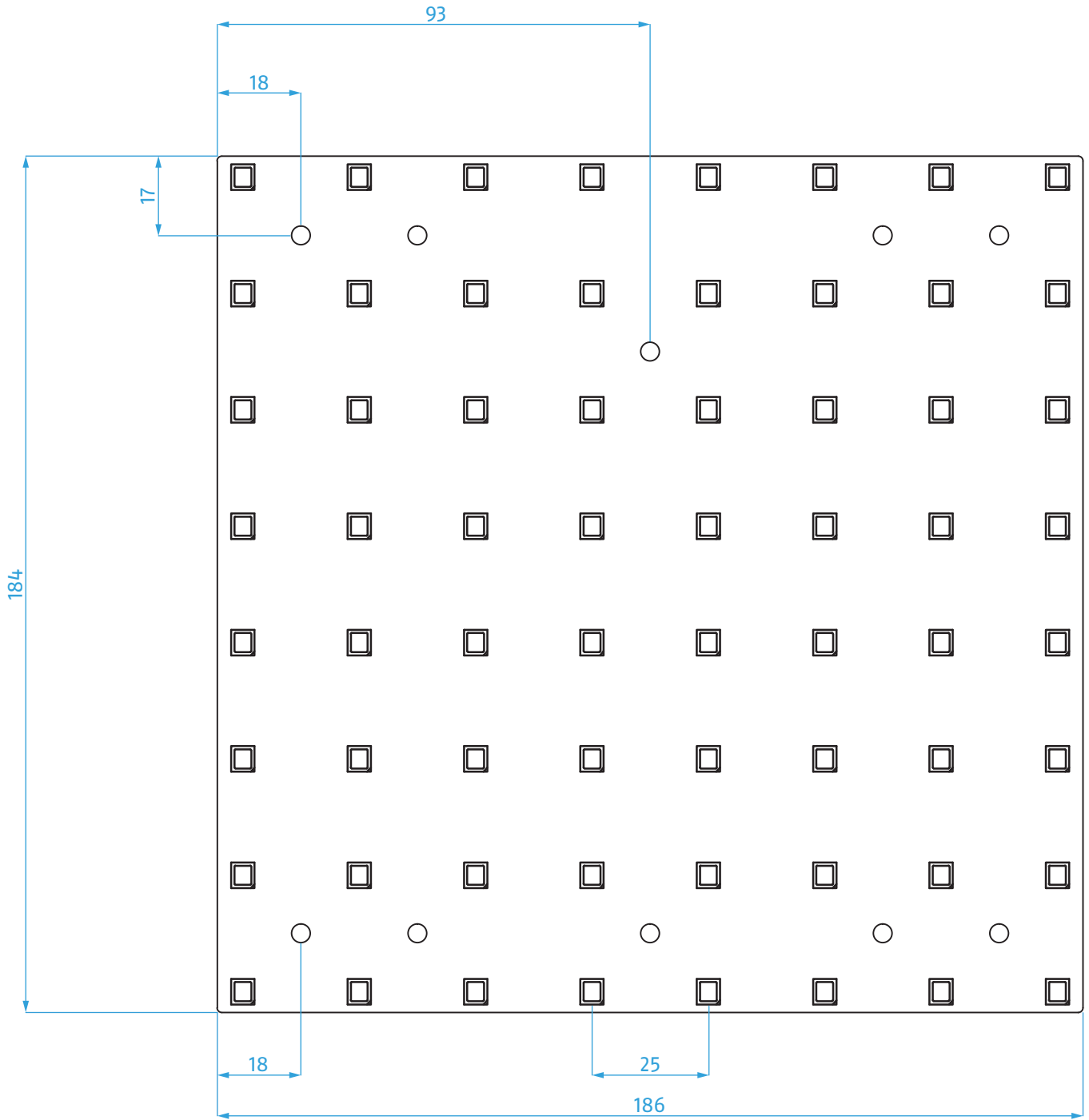

* without scale / all units in mm

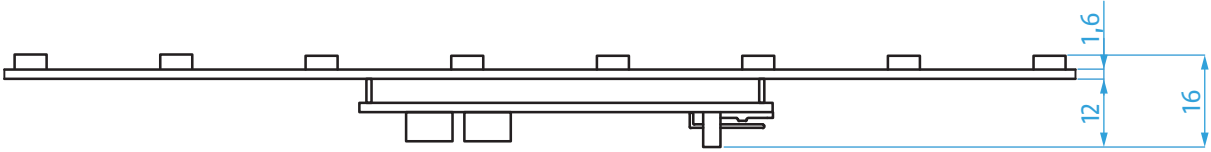
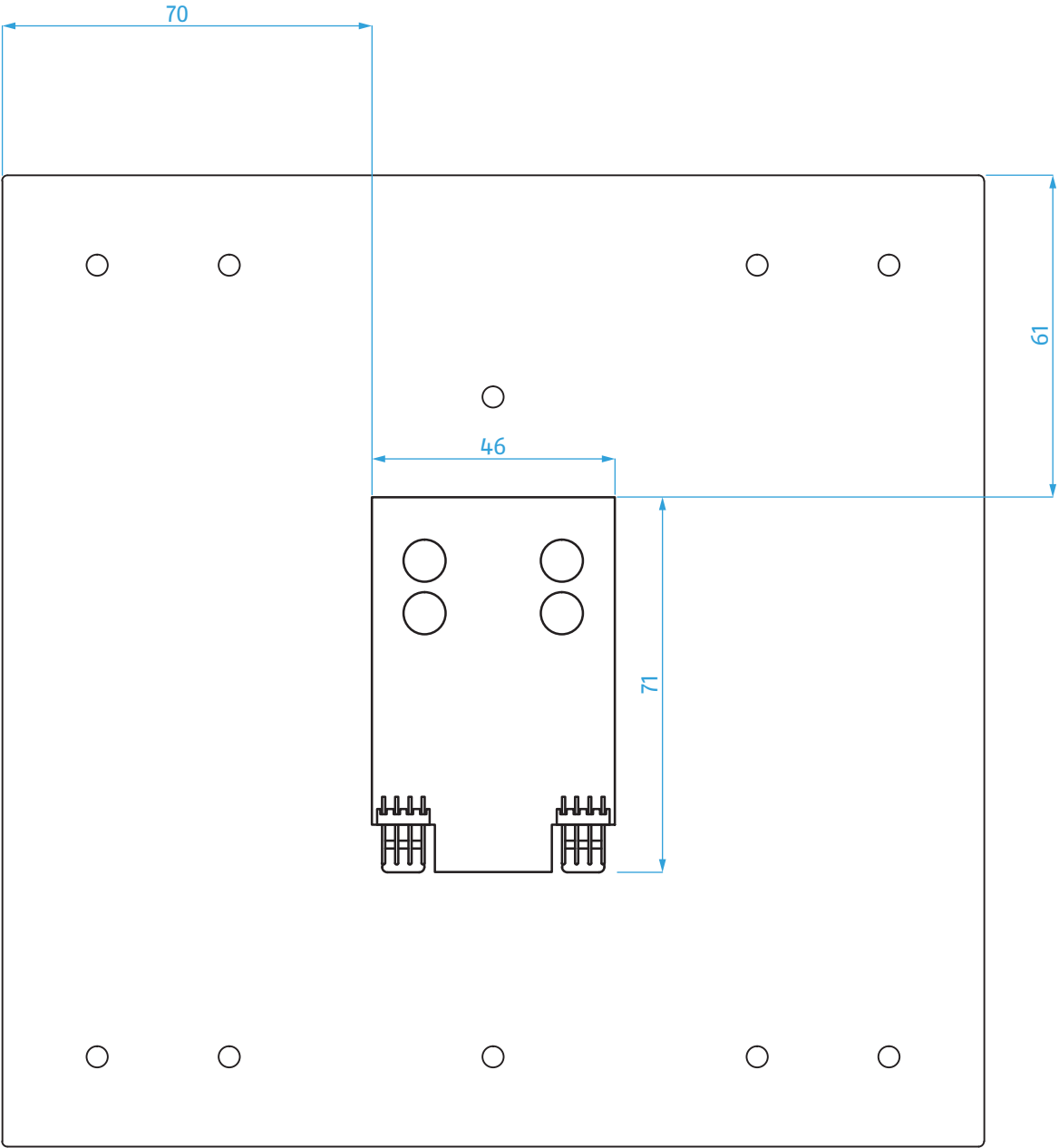

Optical data

Features	LED-Tile C25 MK2.6
Colour	RGB
Emission angle	115°
Lighting current	179,7lm*
Light intensity	76,8cd*

Distance/Lux table

Distance	Lux
0,5m	247,2lx*
1m	61,8lx*
2m	15,4lx*

* The data provided are measured values. As these values are subject to fluctuations, the actual values of the delivered LEDs may deviate from them. The photometric values apply to full white with RGB = 255.

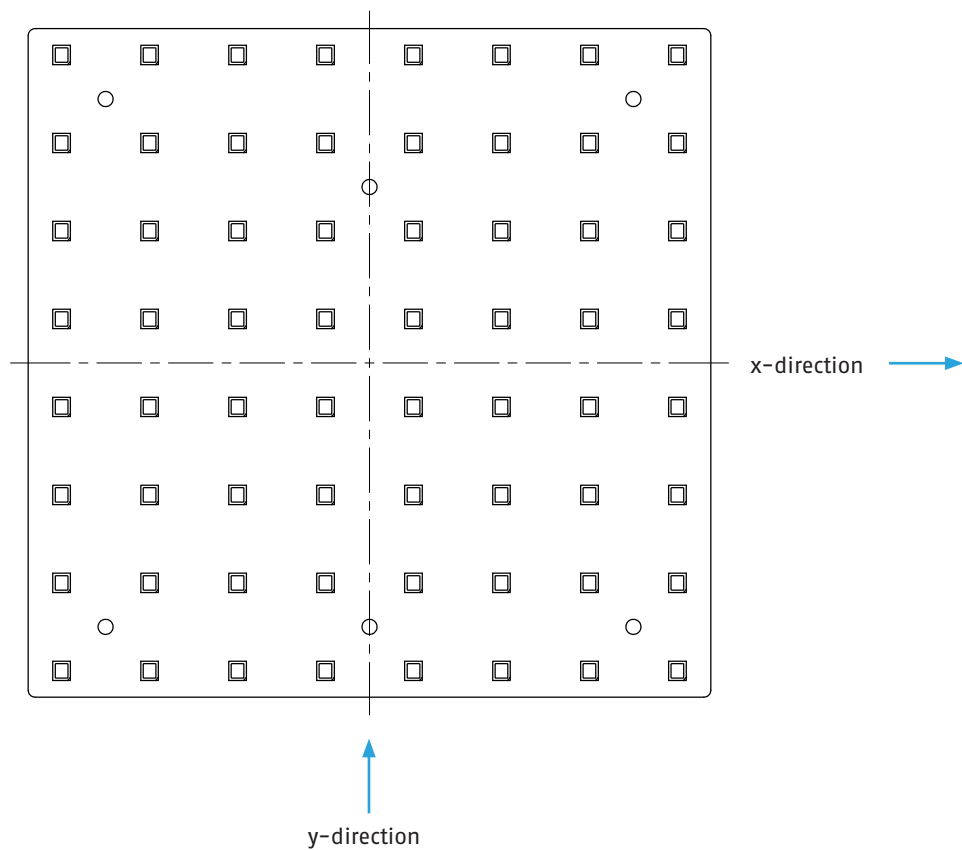

Light distribution curves, x-direction

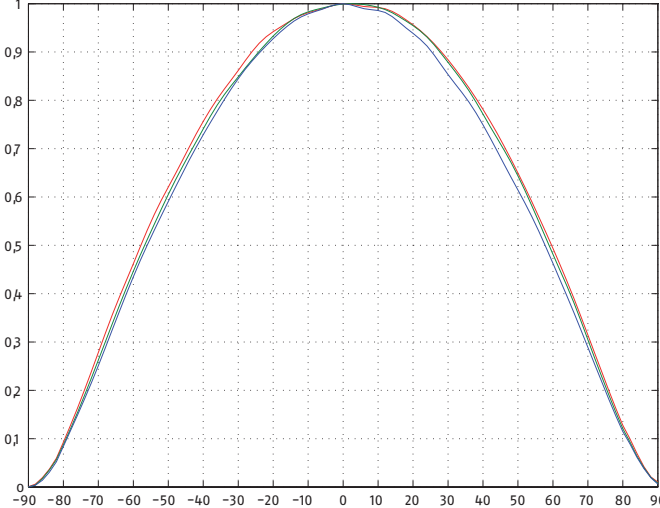
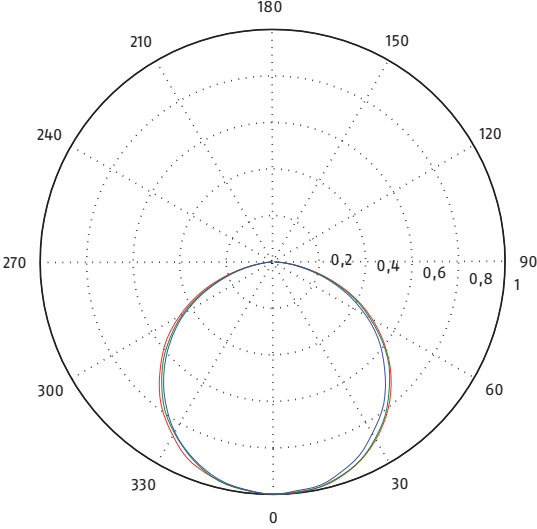

Light distribution curves, y-direction

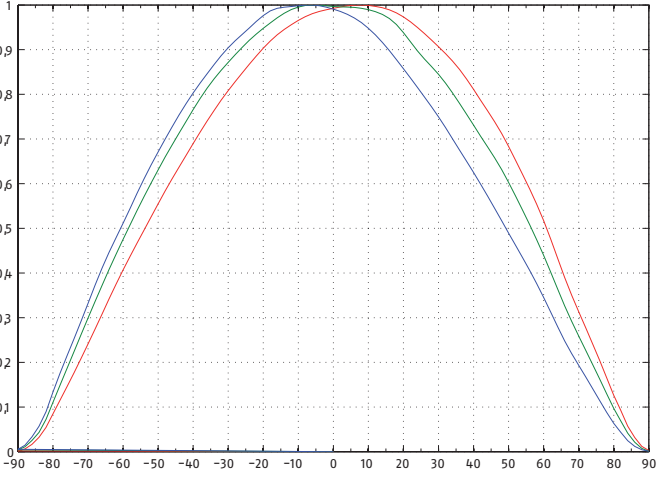
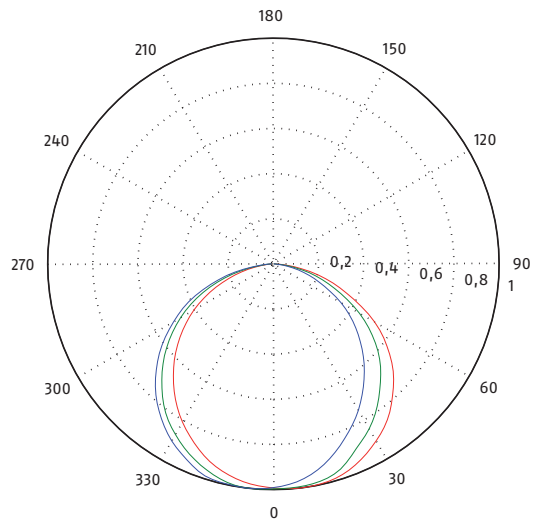

Gamut diagram

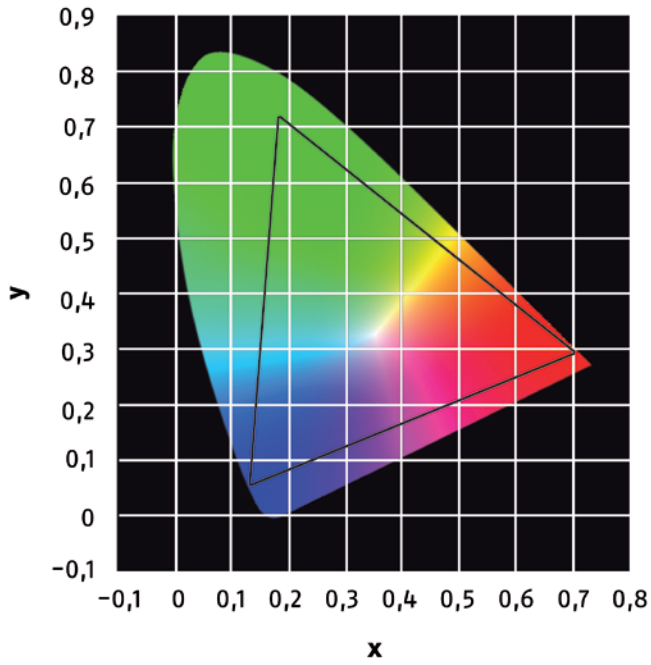

Spectral distribution

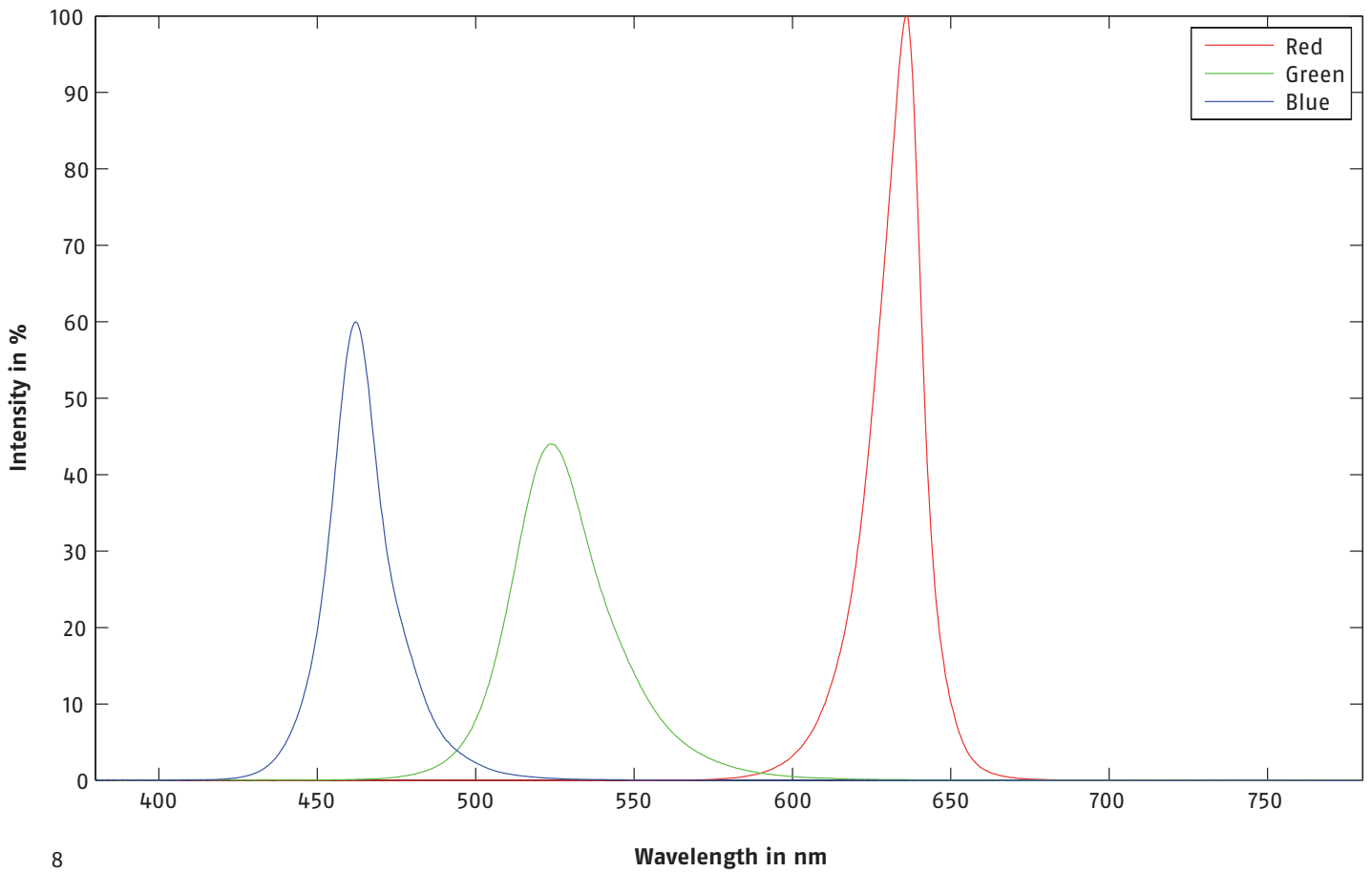

Mounting

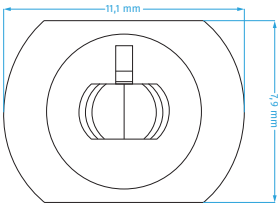
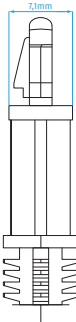
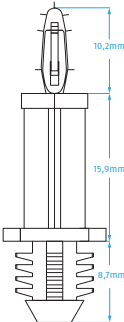

Description	Item number	Drill hole	Material thickness
PCB holder 16mm drill version (for wood or plastic)	802.0008	7,9mm	minimum 6,4mm

Electrical data

Features	LED-Tile C25 MK2.6
Voltage	24V
Current (I_{max})	0,6A

Pin Connection

System connector red

1	■	GND
2	■	DMX -
3	■	DMX +
4	■	24 V

Control options for LED-Tiles C25 MK2.6

System Power Supply 4E



DMX 512*

maximum 8 LED-Tiles per controller
 maximum 2 LED-Tiles per XLR output
 maximum 2 LED-Tiles per system connector red

DPB**

maximum 40 LED-Tiles per controller
 maximum 10 LED-Tiles per XLR-Adapterboard
 maximum 5 LED-Tiles per system connector red

* channel-restricted

** current limited

Cabling example for System Power Supply 4E with LED-Tile C25 MK2.6

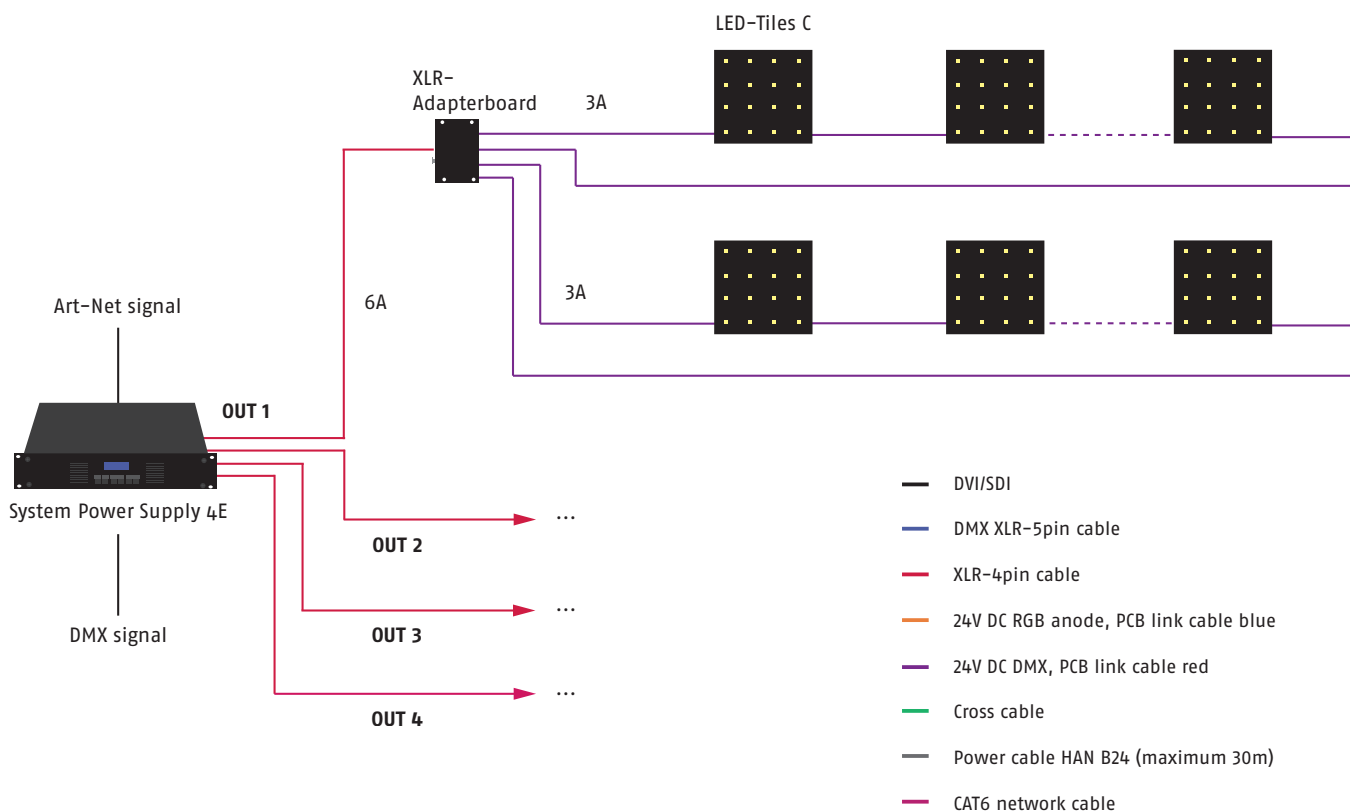

DPB Pixel-Router



DPB

maximum 20 LED-Tiles per controller
 maximum 5 LED-Tiles per output

Cabling example for DPB Pixel-Router with LED-Tile C25 MK2.6

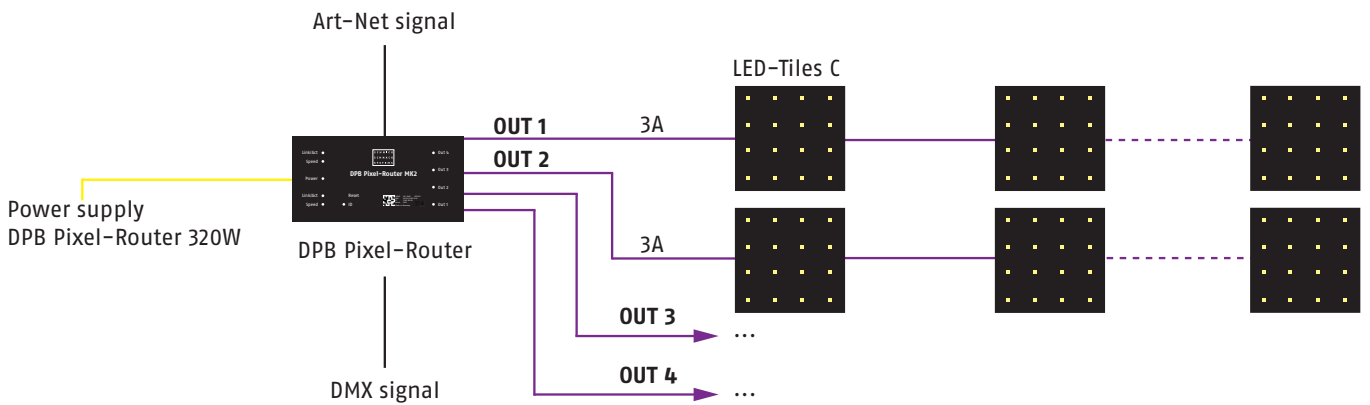

- DVI/SDI
- DMX XLR-5pin cable
- XLR-4pin cable
- 24V DC RGB anode, PCB link cable blue
- 24V DC DMX, PCB link cable red
- Cross cable
- Power cable HAN B24 (maximum 30m)
- CAT6 network cable

Order numbers

	Colour	LED-Pitch	Backlighted surface	Current (I_{max})	Channels	Connection	Item number
LED-Tile C25 MK2.6	RGB	25mm	200mm × 200mm	0,6A	192	System connector red	112.2526

	Operating voltage	Power (I_{max})	Channels	Input	Output	Item number
System Power Supply 4E	110-240V AC	4 × 6A*	4 × 3072 channels (DPB) 4 × 512 channels (DMX)	Ethercon RJ 45 XLR-5pol IN/Trough	4 × XLR-4pin	203.0003
DPB Pixel-Router MK2	24V DC	4 × 3A	4 × 3072 channels	RJ 45	4 × System connector red	203.0021
DPB Pixel-Router POE MK2	24V DC	4 × 3A	4 × 3072 channels	RJ 45	4 × System connector red	203.0022

* Note: american version only 4 × 4A at 110V

ESD warning

Please be aware that electrostatic discharges can destroy LED boards, and our experience shows that this does happen. During assembly, we recommend wearing at least one antistatic wrist strap and avoiding static discharges – such as those that arise when removing protective film or dry cleaning acrylic glass, for example – near LEDs! Antistatic materials should be used when packaging the LED boards. Normal bubble wrap or other plastic bags are not suitable.

For reasons of safety and radio shielding, please only use systems we have approved to provide a power supply for our LED components. All technical information is based on the version at the time of printing.

We reserve the right to make technical specifications in terms of a product improvement without prior notice. Printing – even excerpts – requires the written consent of Schnick-Schnack-Systems GmbH.

Why Schnick Schnack Systems?

As installation times become increasingly shorter the complexity of systems simultaneously increases as do the requirements of customers.

We are a supplier who delivers high-quality reliable systems – under tight deadline constraints that are not only quick to install but also simple to operate and service.

Schnick-Schnack-Systems GmbH

Mathias-Brüggen-Straße 79
50829 Cologne (Germany)

Phone +49 (0) 221/99 2019-0
Fax +49 (0) 221/16 85 09-73

info@schnickschnacksystems.com
www.schnickschnacksystems.com

© 2017 Schnick-Schnack-Systems GmbH

Version October 2017: All technical data and the weight and dimension information were carefully created – errors reserved. Any colour deviations are printing-related.

We reserve the right to make changes that serve further improvement.