

SCHNICK
SCHNACK
SYSTEMS

Case Study

Company Museum MANN + HUMMEL
Filter Wall

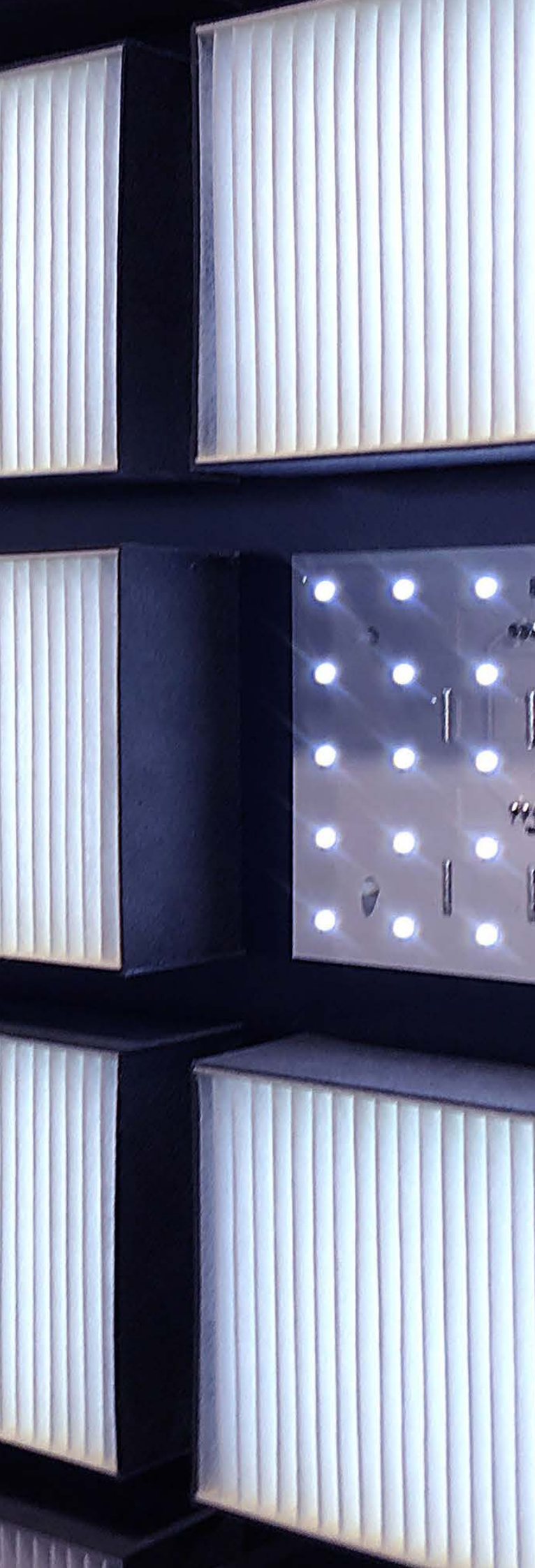

Project

Permanent Exhibition: LED wall with
backlit filter elements

Installed Technology

LED-Tile L20, LED Intelligence,
System Power Supply 4E, Pixel-Gate Light

In Operation

1. July 2016

Partner

Design and Concept of the wall

Holzer Kobler Architekturen Berlin GmbH
Köpenicker Str. 48/49
Door F
D-10179 Berlin

Studio TheGreenEyl GbR
Prinzessinnenstr. 20
Staircase A
D-10969 Berlin

Installation

inSynergie GmbH
Maarweg 56
D-53619 Rheinbreitbach

Reference Customer

MANN + HUMMEL Technology Center
Hindenburgstraße 45
D-71638 Ludwigsburg

Photography

Studio TheGreenEyl

The Project.

The Communicating Filter

The name MANN + HUMMEL resonates – and not only with the automobile manufacturers and auto repair workshops worldwide that use the filter made by this traditional company.

Just in time to mark the firm's 75th anniversary, the market leader in filter technology opened its new technology center in their home base of Ludwigsburg, Germany. This is where the company conducts its research and development and also runs a corporate museum that immerses the visitor in 75 years of company history. Many exhibits and interviews with contemporary witnesses bring MANN + HUMMEL's rise to a global player alive.

Over and over, the product remains the focus: the filter is the center of attention in architecturally elaborately designed rooms. At the heart of the architecture the filter is the optical godfather: we're talking about a stunning LED wall that looks as though it were made out of thousands of illuminated filters. It's 16 meters wide and five meters high. 5,670 L20 LED tiles are arranged in a grid and each is covered with a diffuser that is backlit and therefore the surface of each one resembles a modern filter.

However, it's not just about the lighting: the Filter Wall can also communicate! As part of a guided tour, it informs visitors to the technology center with facts and figures about MANN + HUMMEL. Animation, bar charts, graphics and an abstract world map are part of its repertoire, as well as revolving illuminated lettering that groups the shown content in a range of topics.

"The Communicating Filter" was planned and designed by Holzer Kobler Architekturen Berlin and TheGreenEyl. inSynergie was responsible for the installation.



MANN + HUMMEL

PRO SE

Eye catcher and information center in one: 5,670 monochrome LED Tiles from Schnick-Schnack-Systems illuminate a surface of 80 square meters and are able to transport company content. The diffusors imitate the product that is responsible for MANN + HUMMEL'S rise to a global player: the filter. The completion of this ambitious project took nearly two years.

UMSATZ

MIAR

100

2012

2013

K

The Job Profile. Each individual diffuser is a perfect center of attention.

Detailed work was called for in order to achieve the overall desired effect with the 5,670 individually backlit single elements. From the start, two things were sure: LED Tiles should be used. And, edged with black fleece that prevents the cross-talk effect of neighboring tiles, they should be covered with a special diffuser that is reminiscent of a filter's surface, a direct association with the product is created.

The diffusors, that strongly influence the visual appearance and that create the product association, were produced by MANN + HUMMEL according to the specifications provided by TheGreenEyl. The search for LED technology that could fulfill all of the ambitious project requirements ended with Schnick-Schnack-Systems.

Detailed requirements for the lighting technology:

- High luminous intensity
- Tile form
- Homogenous surface illumination of the diffusers
- Exceptional representation of white and monochromatic light
- Separated installation of the power supply

The project partner chose the LED-Tile L20 – the realization could begin.

The Solution. Powerful, flexible and cost-effective.

The LED Tile L20's high luminous intensity alone was a convincing factor. It offers the best possible light output that is essential in a daylight environment such as the technology center. What's more, the tile's monochrome technology is designed from the beginning to be group controlled as a Pixel. This is what makes the L20 more cost-effective than other tiles where each LED has to be controlled individually. The control technology is also less complex. Lastly, the L20 also offered the desired possibility to install the power supply in a separate room.

In order to simplify the construction of the convex LED wall, TheGreenEyl developed a module concept for the pre-production of larger components. One module consists of 3 × 21 L20 Tiles in a 10 × 10 cm format. Twelve mm through-hole board holders are used to mount tiles, Intelligence boards and Wago adapter boards onto 1.5 mm thick, matt black powder-coated aluminum sheets. Thanks to the monochrome operation, three tiles are thereby on one Intelligence.

In each case, two modules are installed on the wall one above the other. To keep signal delay to a minimum, they are cabled in rows so that two rows that are on top of each other always share one Wago adapter board.

A Pixel-Gate Light is used to control the entire board. Power and data supply are provided by 33 Power Supply 4Es. The control technology and power supplies are in an adjoining technology room, together with a capable PC that has special control software programmed by TheGreenEyl for playing generative real-time animations: a graphical user interface enables data and scenes to be updated and arranged in a time-line. A generative 19-channel sound design provides the appropriate background music.

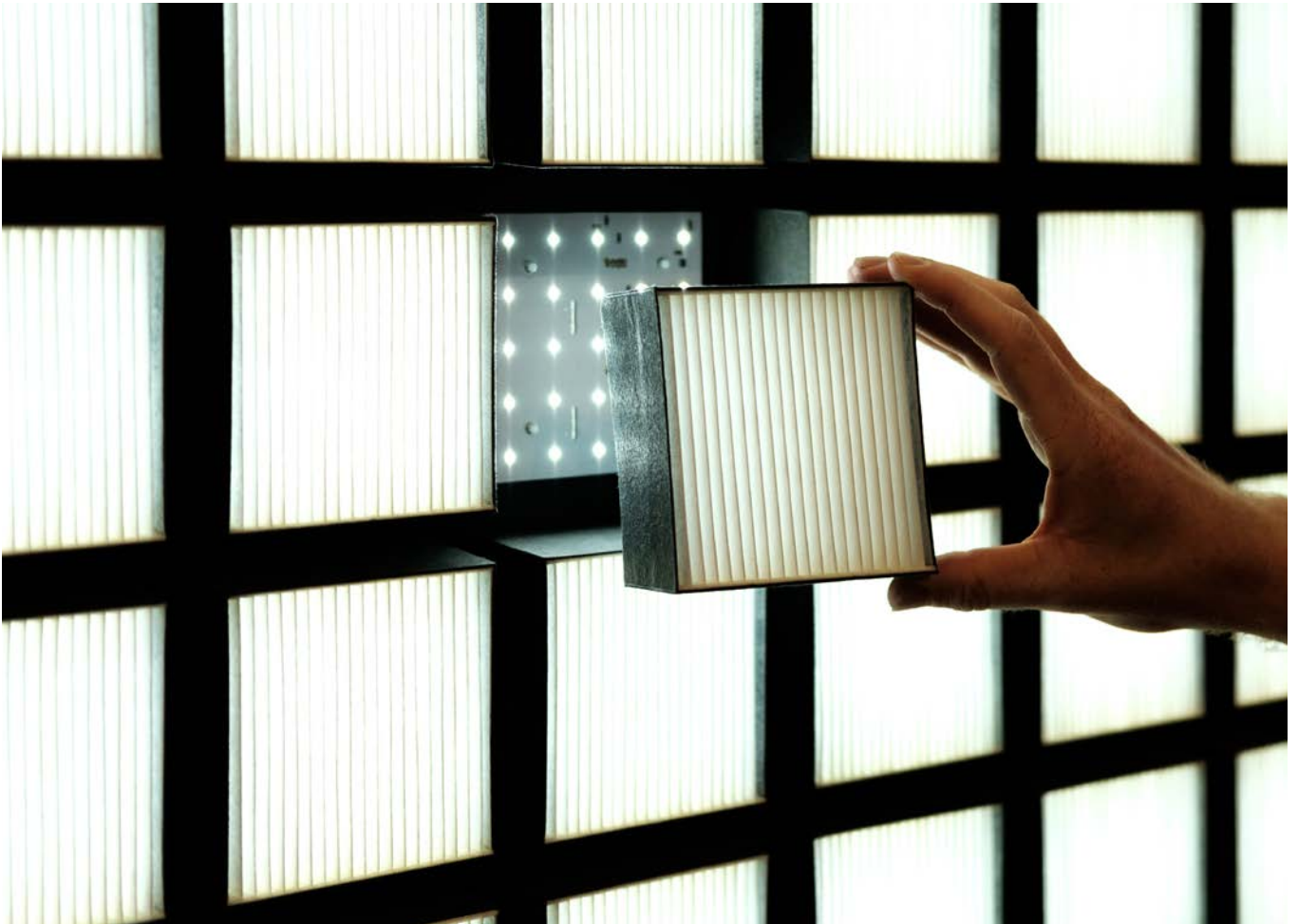

Above Deceptively real, the diffuser imitates the look of a standard filter.

Left Control technology and power supplies are housed in an adjoining room.

The Cabling*

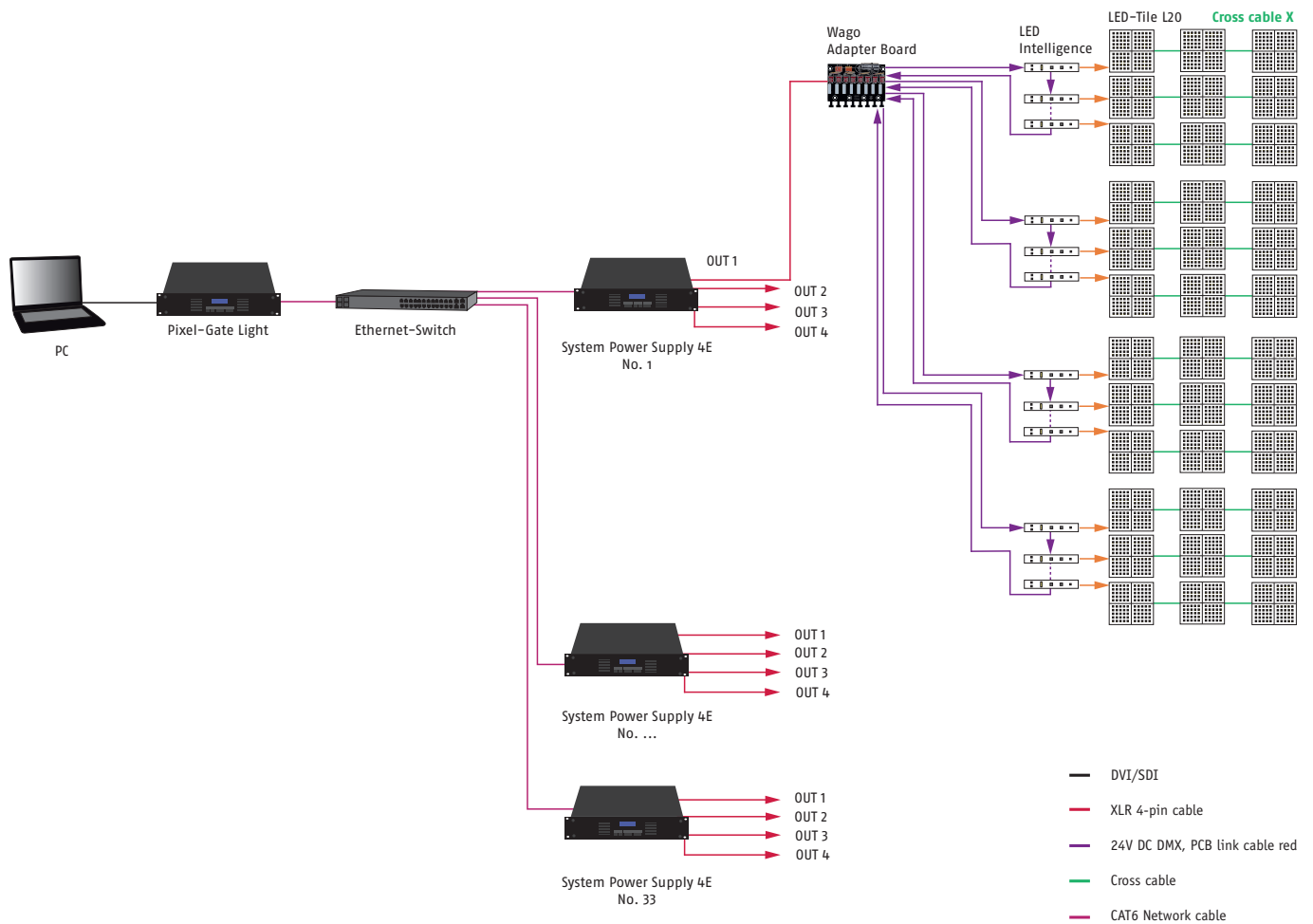

* simplified depiction

Why Schnick-Schnack-Systems?

As installation times become increasingly shorter, systems are becoming increasingly complex in order to meet growing customer expectations.

We are a partner, who delivers premium quality, reliable systems under tight deadline constraints that are not only quick to install but are also simple to operate and service.

Schnick-Schnack-Systems GmbH

Mathias-Brüggen-Straße 79
50829 Cologne (Germany)

Phone +49 (0) 221/99 2019-0
Fax +49 (0) 221/16 85 09-73

info@schnickschnacksystems.com
www.schnickschnacksystems.com