

SCHNICK  
SCHNACK  
SYSTEMS



# USER GUIDE

Units

System Power Supply 4E



Overview	4
Connectivity	5
Installation	
System Cabling	
Cabling Example	6
Menu	7
Menu Order	8
Menu Selection	9
Info	
Manual Patch	
QuickPatch ArtNet	10
QuickPatch DMX	
Combine- and Repeat Modes	11
Setup Menu	12
Output Type	
Colour Gain	
Test Menu	13
Manual RGB	
ArtNet Monitor	14
ArtNet Test Mode	
Demo Mode Fast/Slow	15
Factory Defaults	16
Error Messages	
Software Update	17
Technical Data	18
Pin Connections	
Declaration of EU conformity	19
Conversion table ArtNet Universes	20-25

## Overview

The System Power Supply 4E supplies Schnick-Schnack-Systems' Series B and Series C products with power and data.

The System Power Supply 4E has four, independent XLR4-Pin outputs each of which can supply up to ten LED-Tiles C50, 17 LED Strips C25-250 or 17 LED Strips C50-500. In Series C products the LEDs can be individually controlled.

Each output can supply one LED-Panel C60-50 or C60-25. Once again with these products each LED can be individually controlled.

The System Power Supply 4E can also supply all Series B products by Schnick-Schnack-Systems.

Up to 20 LED-Tiles B or eight meter of LED-Strips B25-250 with Intelligencecan be connected to each output.

The System Power Supply 4E can be controlled by either ArtNet or DMX 512 data and is therefore compatible with most lighting consoles and media servers.

The control signal can be freely patched across the four outputs.

It is also possible to use the System Power Supply 4E as a stand-alone unit, without a DMX or ArtNet control signal.

## Connectivity

The following connectors are located at the rear of the unit:

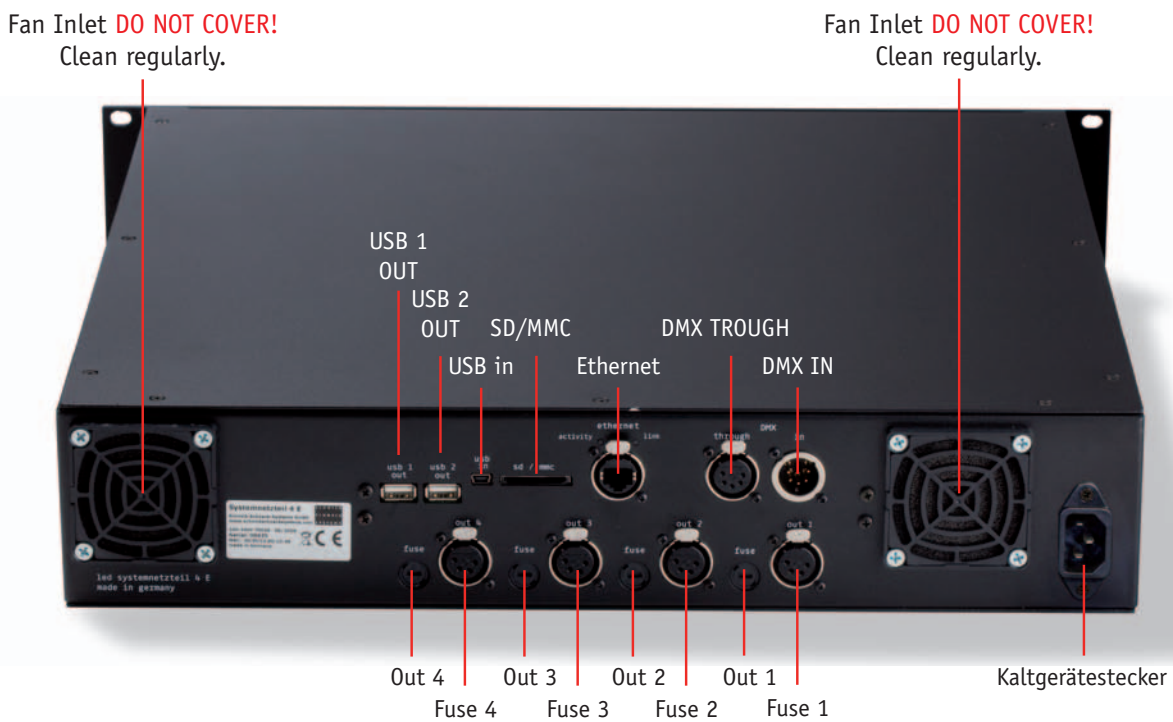

<b>DMX In- and Output</b>	Neutrik XLR5-Pol	<b>SD Card Slot</b>	Used for software updates
<b>ArtNet Input</b>	Neutrik Ethercon	<b>LED Output 1-4</b>	Neutrik 4Pol XLR
<b>Mini USB Input</b>	Reserved for future use	<b>Power Connection</b>	IEC plug
<b>2x USB Output</b>	Reserved for future use		

## Installation

---

Check the device for any damage incurred during transit immediately after unpacking. A damaged unit must not be put into operation.

If the System Power Supply 4E has been taken from a cold environment into a warm interior after transportation, allow at least three hours for it to warm up before it is put into operation. Because of that, possibly formed condensation can evaporate and the electronics are therefore not endangered.

When installing into a rack, ensure that there is sufficient circulating air supply to the front and rear sides. The supply air temperature should not exceed 35°C.

The System Power Supply 4E is to be fitted into the rack installation using the appropriate rails so that the rack-bars take the load off the front panel of the Long Distance Controller and the unit is clearly accessible for maintenance. Be sure to successively lock the cable connections for the DMX in- and output as well as the necessary LED outputs, when connecting cables.

After all connections are made, turn on the device, ensuring that any power is also turned on at the sub-distribution. After approximately one second the System Power Supply 4E is ready for use.

Keep the unit out of direct sunlight at all times. Never clean the device with aggressive cleaners. For cleaning purposes, the wiping of the device with a moist cloth is sufficient.

In the case of stubborn dirt, a mild cleaner can be used on the moistened cloth.

### Cleaning of air filters

No tools are necessary in order to clean the air filters. The fan guard can be removed easily by hand. After that the filter cartridge can be removed and cleaned using compressed air for example. The filter cartridge can then be replaced before refitting the fan guard. Please only use original filters.

## System Cabling

---

Cabling of system is very simple although the following points should be considered:

Schnick-Schnack-Systems' LED illuminants connect to each another using four pin PCB connectors, which are small, lightweight and ideal for this purpose.

The conductor cross-section and the mechanical quality of these cables are not suitable for long and durable leads. Therefore be used rugged XLR 4Pin cables that have two wires with large cross-section as well as a shielded twisted pair for data connection.

Each output of the System Power Supply 4E controls up to 512 DMX channels. This equates to:

ten LED-Tiles C or  
17 LED-Strips C25-250 or up to  
32 LED-Strips L with Intelligence card or  
one LED-Panel C60

Each output of the adapterboard can supply a maximum of 3A. This equates to:

ten LED-Tiles B or  
ten LED-Tiles C or  
16 LED-Strips B25-250 with Intelligence card

Please note: The length of the XLR 4pin cable between the System Power Supply and the XLR4 adapterboard should not be longer than 20m.

The total length of system PCB cable run from the System Power Supply should not exceed 6m.

The exact number of the product can be calculated using the respective current consumption.

## Cabling example

The schematic representation serves as a parts overview for the cabling examples given below.

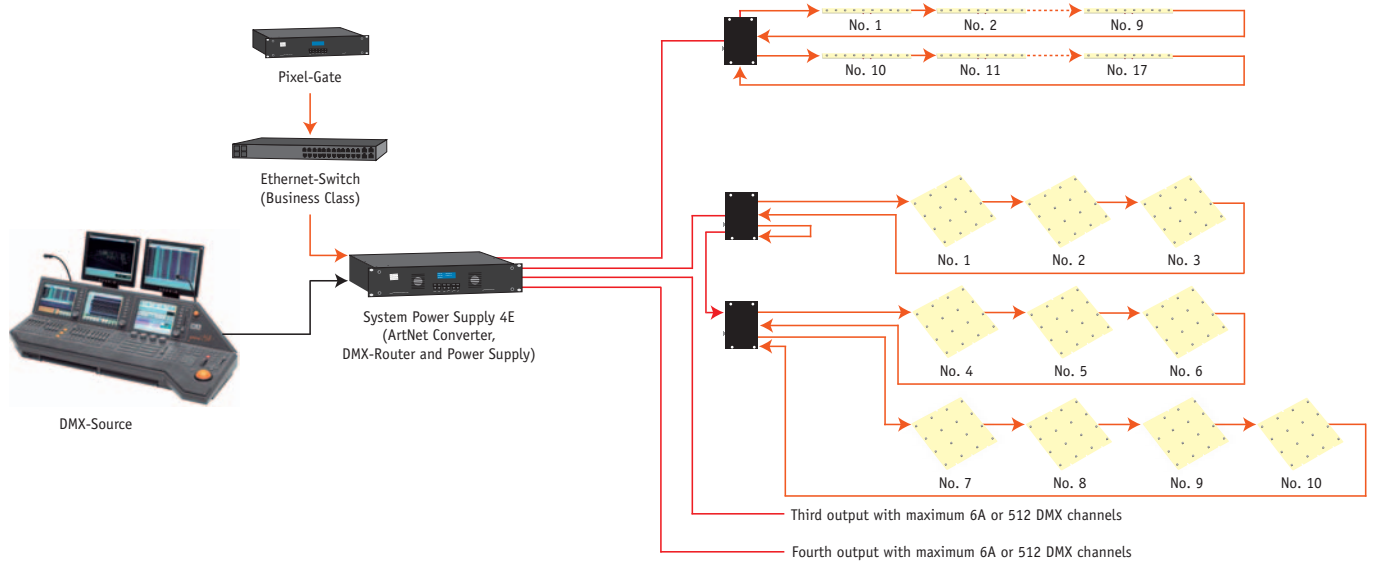

- Power and DMX 4Pin cable
- PCB cable
- CAT 6 cable

## Menu

---

The following connections are located on the front of the unit:



**SHIFT+** used in conjunction with...

**EDIT** to move the cursor backwards through the data fields

**ENTER** to confirm certain actions

**EDIT** moves the cursor through the data fields

**QUIT** exists the currently-selected mode

**ENTER** to confirm certain actions e. g. mode changes

**UP** moves upward through the mode list. Increases the value in the selected data field

**DOWN** moves downwards through the mode list. Decreases the value in the selected data field

## Menu Order

---

<p>Temp. <b>Welcome to Systemnetzteil 4E</b> IP v 2.6</p>	<p><b>Main Menu:</b> Info</p>
<p>*</p>	<p><b>Main Menu:</b> Manual Patch</p>
<p></p>	<p><b>Main Menu:</b> QuickPatch ArtNet</p>
<p>*</p>	<p><b>Main Menu:</b> QuickPatch DMX</p>
<p></p>	<p><b>Main Menu:</b> Setup Menu</p>
<p></p>	<p><b>Main Menu:</b> Test Menu</p>
<p></p>	<p><b>Main Menu:</b> Factory Defaults</p>

\* Output Typ S3-DMX: Manual Patch and QuickPatch DMX are not necessary



## Menu Selection

---

To change mode, press the **QUIT** button the display will show **CHANGE MODE?**

Confirm the action by pressing the **ENTER** button or cancel by pressing the **QUIT** button again.

Use the **UP** and **DOWN** buttons to select the desired mode.

Confirm selection by pressing the **ENTER** button or press the **QUIT** button to return to the most recently used mode.

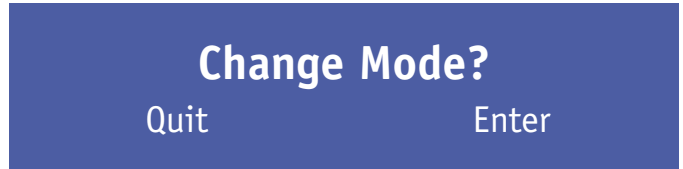

## Info

---

This mode displays the unit type and installed software version.

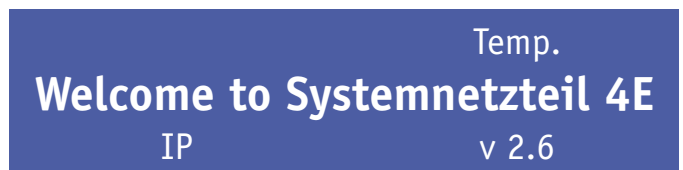

## Manual Patch

---

When changing from the QuickPatch mode into the Manual Patch mode the following display is shown:

This mode offers the user the opportunity to overwrite the DMX channels set by the QuickPatch mode with channels of their own choice.

Please note that this operation is irreversible **SHIFT+ENTER** must be pushed together, in order to confirm the channel selection, otherwise press **QUIT** to exit the mode.

### Setting values in Manual Patch mode:

Use the **OUT** field to select the output to be patched (1-4). Use the **CH** field to assign a DMX start address to the selected.

In the **TYPE** field select **INT** to allow an output level to be set manually.

Select **TYPE: DMX** to allow control of the output via DMX.

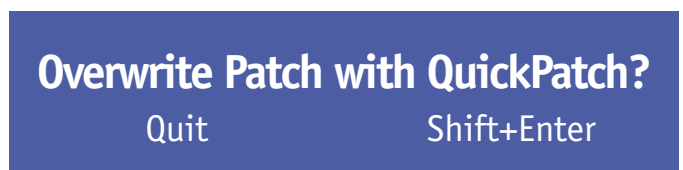

## QuickPatch ArtNet

---

For each output two data fields are shown on the display. The upper field displays the ArtNet universe as a decimal number.

The lower field displays the DMX start address for the universe in the data field above it (if the information of a universe may need to be patched across more than one output).

A control check mark in a square by each output number, denotes the presence of valid ArtNet data at that output.

The first valid universe is 0.

	OUT 1	OUT2	OUT3	OUT4
Universe	0	1	2	3
Start-Ch:	1	1	1	1

## QuickPatch DMX

---

For each output two data fields are shown on the display.

The upper field shows the DMX start channel (**start CH:**) for that output.

The lower field offers the opportunity to combine subsequent channels into regularly repeating groups. Use the **EDIT** button to select the required field.

The DMX field shows the status of the incoming DMX signal.

**NONE** shows that no DMX signal is being received.

**GOOD** shows that a valid DMX signal is being received.

The table on the following page shows the various repeat and combine options available via the menu system.

	OUT 1	OUT2	OUT3	OUT4
DMX: None				
Start-Ch:	1	1	1	1
Combine:	OFF	OFF	OFF	OFF

## Combine and Repeat Modes

- OFF: no combine
- ALL: all LEDs are steered by three DMX channels
- C2: always two LEDs are interconnected
- C3: always three LEDs are interconnected
- C4: always four LEDs are interconnected
- C5: always five LEDs are interconnected
- C6: always six LEDs are interconnected
- C7: always seven LEDs are interconnected
- C8: always eight LEDs are interconnected
- C9: always nine LEDs are interconnected
- C10: always ten LEDs are interconnected
- R2: each second LED is interconnected
- R3: each third LED is interconnected
- R4: each fourth LED is interconnected
- R5: each fifth LED is interconnected
- R6: each sixth LED is interconnected
- R7: each seventh LED is interconnected
- R8: each eighth LED is interconnected
- R9: each ninth LED is interconnected
- R10: each tenth LED is interconnected

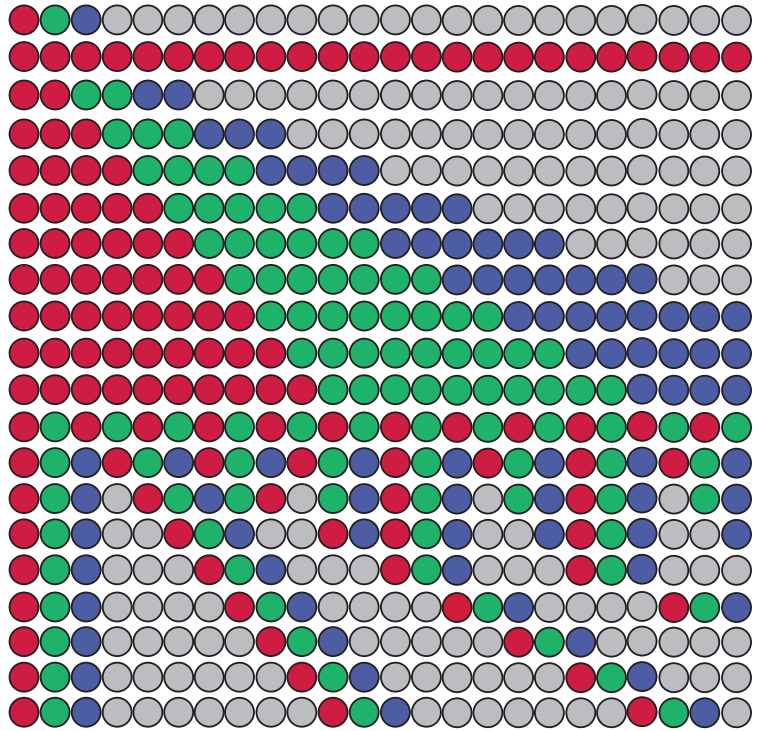

## Setup Menu

---

The Setup Menu is divided into:

**Setup Menu:**

Output

Gain

## Output Type

---

Switch between standard DMX 512 or S3-DMX for the enterprise of the LED-Tiles C25 or LED-Panels C60-25.

Like the other modes, use the **EDIT** button to select the required field and the **UP/DOWN** buttons to set the required values.

**Output Type:**

DMX 512

**Output Type:**

S3 DMX

## Colour Gain

---

With this function the colors red, green and blue can be made darker. With 255 this function is deactivated.

**Colour Gain (off: 255)**

R: 255 G: 255 B: 255

## Test Menu

---

The Test Menu is divided into:

Test Menu:

Manual RGB

Test Menu:

ArtNet Monitor

Test Menu:

ArtNet Test TX

Test Menu:

Demo Slow

Test Menu:

Demo Fast

## Manual RGB

---

This mode allows a static, single colour to be set across all connected illuminants, without the need for an incoming DMX signal.

Like the other modes, use the **EDIT** button to select the required field and the **UP/DOWN** buttons to set the required values.

Manual Colour Mode

R: 0 G: 0 B: 0

## ArtNet Monitor

---

**Universes** indicates the first and last sent ArtNet universe.

**Monitor** indicates, with which frequency the adjusted universe sends.

This feature allows to test the frame rate of the respective ArtNet signal.



```
ArtNet Monitor 0.0
Universes
Monitor 0 0.0Hz
```

## ArtNet Test Mode

---

In this mode the System Power Supply 4E will function as an ArtNet data transmitter.

This function was implemented as a means of testing the cables and Ethernet switches used in a system without the need for an external ArtNet data source. In this mode the System Power Supply 4E performs no other functions. There is also no LED control.

In this mode the System Power Supply 4E sends a strobe signal over ArtNet, switching all channels on and off simultaneously.

**The following parameters can be adjusted:**

### **Ton**

The duration of the On-pulse of the strobe impulse in seconds

### **Toff**

The duration of the Off-pulse of the strobe impulse in seconds

### **#uni**

The number of the ArtNet universe, over which data is being sent. In this mode, the System Power Supply 4E will default to the last-used universe

The **STATE** field display, in real time, wheter an **ON** or **OFF** pulse is being sent

While the System Power Supply 4E works in this mode only as an ArtNet transmitter the strobe signal with the separate output is not play.



```
ArtNet Test Mode
Ton      Toff    #uni    State
0.50     1.00    255     Off
```

## Demo Fast/Slow

---

In this mode all connected RGB LEDs will run a preset sequence at one of two speeds selected by the user.

Please note that separate System Power Supply 4E running this mode will not run synchronization with each other.

**Demo Mode Fast**

**Demo Mode Slow**

## Factory Defaults

---

Push **SHIFT+ENTER**. Then the equipment puts back to factory settings.

**Restore Factory Defaults?**  
Quit                      Shift+Enter

## Error Messages

---

If one of the fuses protecting the outputs should fail, the display will flash and show the following type of message.

In this case output is 1 failed. The other output function further.

**Output Error**

	OUT 1	OUT2	OUT3	OUT4
Fuse:	BAD	O.K.	O.K.	O.K.



## Software Update

---

The System Power Supply 4E system software can be updated easily with the latest version using an SD Card.

New software versions keep products up to date with the latest features and are available for download from our website at [www.schnickschnacksystems.com](http://www.schnickschnacksystems.com)

Please read the readme.txt file for details of how to format the software correctly onto an SD Card.

### To update the software version:

1. Turn off the System Power Supply 4E by disconnecting the power cable
2. Insert the SD card slot carrying the software version to be uploaded into the SC Card slot on the rear of the unit
3. Turn the System Power Supply 4E back on by reconnecting the power cable
4. The System Power Supply 4E automatically detects and loads the new software version. The software is updated and the display shows the message: **PLEASE WAIT**
5. When the installation is complete the display shows the welcome message and the new software version number
6. The System Power Supply 4E is now ready to use again
7. Removing the SD card

## Technical Data

---

Housing	19", two height unit
Dimensions	483 x 88 x 430mm (WxHxD)
Input voltage	100-250V AC, 50-60Hz
Power Consumption	700VA
Current Output	6A per output maximum
Main Connector	IEC plug, lockable
Data Protocol	DMX 512 A-1990 USITT
DMX IN	Neutrik XLR5-Pin
DMX THROUGH	Neutrik XLR5-Pin
ArtNet	Neutrik Ethercon
LED outputs 1-4	4x Neutrik XLR4-Pin
Weight	9,5kg

## Pin Connection

---

### DMX

1	2	3	4	5	Housing
Data GND	Data-	Data+	n/c	n/c	n/c

### XLR4-Pin Output

1	2	3	4	Housing
GND	Data-	Data+	+24V	n/c

## Declaration of EU-Conformity

I hereby declare that the product

LED-Beleuchtungssystem bestehend aus „LED-Systemnetzteil 4“, „LED-Kachel B“, „LED Streifen 25“ mit „Intelligenz“ und Verkabelung nach Bedienungsanleitung.

(Name of product, type or model, batch or serial number)

meets the essential requirements referred to in Article 3 of the Council Directive 99/5/EC.

The following harmonized standards have been applied:

EN 60950-1:2003

EN 55015:2000

### MANUFACTURER or AUTHORISED REPRESENTATIVE:

**Address:**

Schnick-Schnack-Systems GmbH

Gunther-Plueschow Strasse 6

50829 Koeln

Germany

Tel.: +49 221 992 019 - 0

Fax.: +49 221 992 019 - 22

Koeln, 7<sup>th</sup>. February 2005

(Place, Date of issue)

  
(Signature)

Dipl. Ing. (FH) Erhard Lehmann

(Name in block letters)

## Conversion table ArtNet Universes

"Artnet Standard (Hexadecimal Numbering)"		"Schnick-Schnack-Systems (Decimal Numbering)"	MA-Lighting Numbering
<i>Subnet</i>	<i>Universe</i>		
0	0	0	1
0	1	1	2
0	2	2	3
0	3	3	4
0	4	4	5
0	5	5	6
0	6	6	7
0	7	7	8
0	8	8	9
0	9	9	10
0	A	10	11
0	B	11	12
0	C	12	13
0	D	13	14
0	E	14	15
0	F	15	16
1	0	16	17
1	1	17	18
1	2	18	19
1	3	19	20
1	4	20	21
1	5	21	22
1	6	22	23
1	7	23	24
1	8	24	25
1	9	25	26
1	A	26	27
1	B	27	28
1	C	28	29
1	D	29	30
1	E	30	31
1	F	31	32
2	0	32	33
2	1	33	34
2	2	34	35
2	3	35	36
2	4	36	37
2	5	37	38
2	6	38	39
2	7	39	40
2	8	40	41
2	9	41	42
2	A	42	43
2	B	43	44
2	C	44	45
2	D	45	46

"Artnet Standard (Hexadecimal Numbering)"		"Schnick-Schnack-Systems (Decimal Numbering)"	MA-Lighting Numbering
<i>Subnet</i>	<i>Universe</i>		
2	E	46	47
2	F	47	48
3	0	48	49
3	1	49	50
3	2	50	51
3	3	51	52
3	4	52	53
3	5	53	54
3	6	54	55
3	7	55	56
3	8	56	57
3	9	57	58
3	A	58	59
3	B	59	60
3	C	60	61
3	D	61	62
3	E	62	63
3	F	63	64
4	0	64	65
4	1	65	66
4	2	66	67
4	3	67	68
4	4	68	69
4	5	69	70
4	6	70	71
4	7	71	72
4	8	72	73
4	9	73	74
4	A	74	75
4	B	75	76
4	C	76	77
4	D	77	78
4	E	78	79
4	F	79	80
5	0	80	81
5	1	81	82
5	2	82	83
5	3	83	84
5	4	84	85
5	5	85	86
5	6	86	87
5	7	87	88
5	8	88	89
5	9	89	90
5	A	90	91
5	B	91	92

## Conversion table ArtNet Universes

"Artnet Standard (Hexadecimal Numbering)"		"Schnick-Schnack-Systems (Decimal Numbering)"	MA-Lighting Numbering
<i>Subnet</i>	<i>Universe</i>		
5	B	91	92
5	C	92	93
5	D	93	94
5	E	94	95
5	F	95	96
6	0	96	97
6	1	97	98
6	2	98	99
6	3	99	100
6	4	100	101
6	5	101	102
6	6	102	103
6	7	103	104
6	8	104	105
6	9	105	106
6	A	106	107
6	B	107	108
6	C	108	109
6	D	109	110
6	E	110	111
6	F	111	112
7	0	112	113
7	1	113	114
7	2	114	115
7	3	115	116
7	4	116	117
7	5	117	118
7	6	118	119
7	7	119	120
7	8	120	121
7	9	121	122
7	A	122	123
7	B	123	124
7	C	124	125
7	D	125	126
7	E	126	127
7	F	127	128
8	0	128	129
8	1	129	130
8	2	130	131
8	3	131	132
8	4	132	133
8	5	133	134
8	6	134	135
8	7	135	136
8	8	136	137

"Artnet Standard (Hexadecimal Numbering)"		"Schnick-Schnack-Systems (Decimal Numbering)"	MA-Lighting Numbering
<i>Subnet</i>	<i>Universe</i>		
8	9	137	138
8	A	138	139
8	B	139	140
8	C	140	141
8	D	141	142
8	E	142	143
8	F	143	144
9	0	144	145
9	1	145	146
9	2	146	147
9	3	147	148
9	4	148	149
9	5	149	150
9	6	150	151
9	7	151	152
9	8	152	153
9	9	153	154
9	A	154	155
9	B	155	156
9	C	156	157
9	D	157	158
9	E	158	159
9	F	159	160
A	0	160	161
A	1	161	162
A	2	162	163
A	3	163	164
A	4	164	165
A	5	165	166
A	6	166	167
A	7	167	168
A	8	168	169
A	9	169	170
A	A	170	171
A	B	171	172
A	C	172	173
A	D	173	174
A	E	174	175
A	F	175	176
B	0	176	177
B	1	177	178
B	2	178	179
B	3	179	180
B	4	180	181
B	5	181	182
B	6	182	183

## Conversion table ArtNet Universes

"Artnet Standard (Hexadecimal Numbering)"		"Schnick-Schnack-Systems (Decimal Numbering)"	MA-Lighting Numbering
<i>Subnet</i>	<i>Universe</i>		
B	7	183	184
B	8	184	185
B	9	185	186
B	A	186	187
B	B	187	188
B	C	188	189
B	D	189	190
B	E	190	191
B	F	191	192
C	0	192	193
C	1	193	194
C	2	194	195
C	3	195	196
C	4	196	197
C	5	197	198
C	6	198	199
C	7	199	200
C	8	200	201
C	9	201	202
C	A	202	203
C	B	203	204
C	C	204	205
C	D	205	206
C	E	206	207
C	F	207	208
D	0	208	209
D	1	209	210
D	2	210	211
D	3	211	212
D	4	212	213
D	5	213	214
D	6	214	215
D	7	215	216
D	8	216	217
D	9	217	218
D	A	218	219
D	B	219	220
D	C	220	221
D	D	221	222
D	E	222	223
D	F	223	224
E	0	224	225
E	1	225	226
E	2	226	227
E	3	227	228
E	4	228	229



"Artnet Standard (Hexadecimal Numbering)"		"Schnick-Schnack-Systems (Decimal Numbering)"	MA-Lighting Numbering
<i>Subnet</i>	<i>Universe</i>		
E	5	229	230
E	6	230	231
E	7	231	232
E	8	232	233
E	9	233	234
E	A	234	235
E	B	235	236
E	C	236	237
E	D	237	238
E	E	238	239
E	F	239	240
F	0	240	241
F	1	241	242
F	2	242	243
F	3	243	244
F	4	244	245
F	5	245	246
F	6	246	247
F	7	247	248
F	8	248	249
F	9	249	250
F	A	250	251
F	B	251	252
F	C	252	253
F	D	253	254
F	E	254	255
F	F	255	256

## **Why Schnick Schnack Systems?**

As installation times become increasingly shorter the complexity of systems simultaneously increases as do the requirements of customers.

We are a supplier who delivers high-quality reliable systems –under tight deadline constraints that are not only quick to install but simple to operate and service also.

**Schnick-Schnack-Systems GmbH**  
Mathias-Brüggen-Straße 79  
50829 Cologne (Germany)

Phone: +49 (0) 221/99 20 19-0  
Fax: +49 (0) 221/16 85 09-73

[info@schnickschnacksystems.com](mailto:info@schnickschnacksystems.com)  
[www.schnickschnacksystems.com](http://www.schnickschnacksystems.com)